



Plasma &

Reactive Gas
Solutions

WWW.MKSINST.COM

LIQUOZON[®] Single

OZONATED WATER DELIVERY SYSTEM THE MOST COMPACT SYSTEM AVAILABLE

LIQUOZON[®] Single Ozonated Water Delivery System is the most compact source available today for wet wafer processing with ozone. It is especially suited for single wafer applications.

The new, compact Single Series was designed for low flow applications with ozone concentrations up to 95 ppm such as wet wafer cleaning, contaminant removal, surface conditioning and oxide growth. The small footprint of the Single Series makes it uniquely suited to single wafer applications, as well as many immersion applications. As part of the production proven family of LIQUOZON systems, the Single Series also has the same highly reliable ozone generating and contacting technology.

Features & Benefits

Compact Footprint with Excellent Performance

- Extremely compact size of only 400 x 500 x 1200 mm
- Up to 95 ppm dissolved ozone
- Ozonated water flow up to 20 lpm
- Constant ozone concentration and operating pressure at varying flow rates
- Ultra-clean for semiconductor processing applications
- Long ozone lifetime in water

Faster, Easier Installation, System Integration and Operation

- Simple operation via Touch Screen
- No analyzer or cabinet drain connection required

Clean, Safe Alternative to Conventional Chemical Processing

- High redox potential of ozone
- Can be generated at point-of-use
- Green chemical easily converted back to oxygen

Low Cost of Ownership

- Reduced chemical consumption and disposal costs
- Lower UP water consumption
- Low O₂, CDA, cooling water and exhaust consumption
- Supports single or multiple process tools for maximum efficiency

Proven Reliability

- Industry leading ozone generating technology
- MTBF > 20,000 hours



Ozone is an environmentally friendly alternative to many process chemicals in the semiconductor industry. It has a high redox potential, can be generated at the point-of-use and is easily converted back to oxygen. Cost of purchase, storage and disposal of many chemicals can thus be reduced considerably.

The LIQUOZON® Family

In addition to the LIQUOZON Single Series, the LIQUOZON family of ozonated water delivery systems includes the new LIQUOZON Smart Series and the classic long-proven LIQUOZON 100 and XF.

The LIQUOZON family features the field-proven MKS SEMOZON® ozone generation technology, proprietary MKS-designed contactors for unsurpassed dissolving efficiency of ozone gas in water, state-of-the-art controls and an ozone destruct unit for safe re-conversion of residual ozone gas to oxygen. The LIQUOZON systems are enclosed in a vented rack and are S2 and CE compliant.

Closed-loop control ensures delivery of ozonated water at a stable ozone concentration, even at variable flow rates.

LIQUOZON® Single System

The LIQUOZON Single ozonated water delivery system is a self-contained unit that provides DIO_3 water (ultra pure ozonated water) with high, accurate and stable ozone concentration at constant pressure.

The LIQUOZON Single system range offers different options to meet customer-specific needs in the most cost-effective manner including:

- Choice of three different ozone gas generators (performance ranges)
- Optional externally attached ozone leak monitor

The ozone gas generator is part of the highly reliable MKS SEMOZON AX8407 compact series, which produces ozone from oxygen by silent discharge. A minute amount of carbon dioxide (CO_2) is added as a dopant gas to ensure best ozone generation performance. The CO_2 considerably increases the lifetime of ozone in the DI_2 water and is ultra-clean. With CO_2 there is no possibility of formation of NO_x compounds or resultant metal contamination. High quality, ozone-resistant materials and the unique doping technique ensure ultra-clean ozonated water delivery for high purity semiconductor and flat panel applications.

Performance

Concentration and Flow

LIQUOZON Single generates ozonated deionized water (DIO_3) with a pressure of up to 2.5 bar_{gauge} and a volumetric flow rate of up to 20 L/min. At low flow rates (2 L/min) dissolved ozone (O_3) concentration of 95 ppm is achievable; at high flow rates (20 L/min) concentration is a maximum of 30 ppm. The LIQUOZON Single is available with different performance versions.

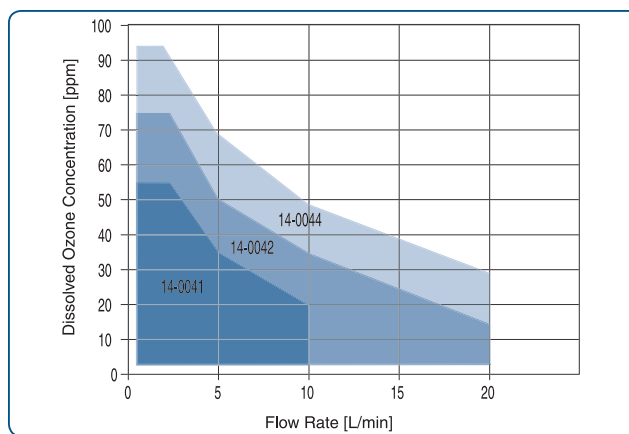

Concentration and Flow Diagram

System Design and Configuration

The integrated SEMOZON ozone gas generator converts oxygen (O_2) partially into ozone (O_3). In the MKS-designed contactor, O_3 dissolves in ultra pure water at high efficiency. Residual undissolved O_3 gas converts safely back to oxygen in the integrated ozone destruct unit. An O_3 analyzer continuously measures O_3 concentration in water and a control loop adjusts the power of the SEMOZON generator to ensure an accurate DIO_3 output concentration.

The ozone gas generator incorporates an inlet for O_2 gas and an outlet for the O_2/O_3 mixture. CO_2 is added to the O_2 gas as a dopant to stabilize the ozone generation performance as well as to stabilize ozone in the deionized water.

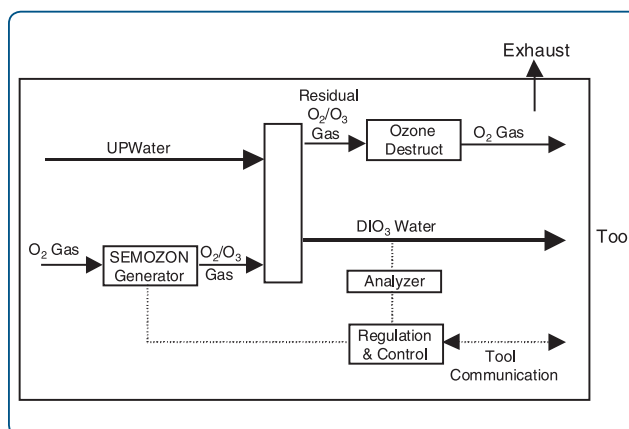

System Flow Diagram



System Response and Accuracy

LIQUOZON systems provide ozonated water at an exceptionally accurate and stable concentration. At flow rate changes, LIQUOZON Single can keep the concentration stable with only a small deviation from point.

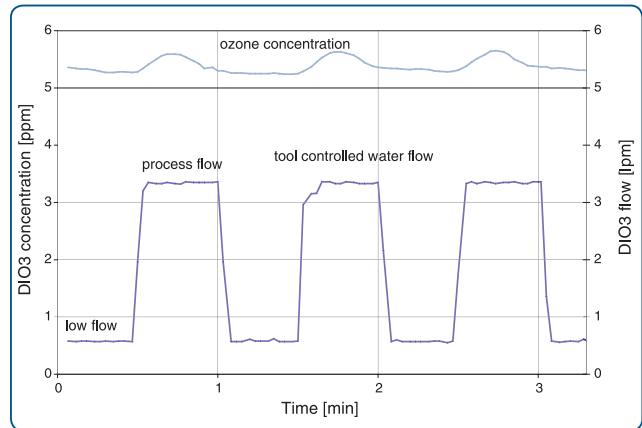

Typical concentration stability during changing flow conditions

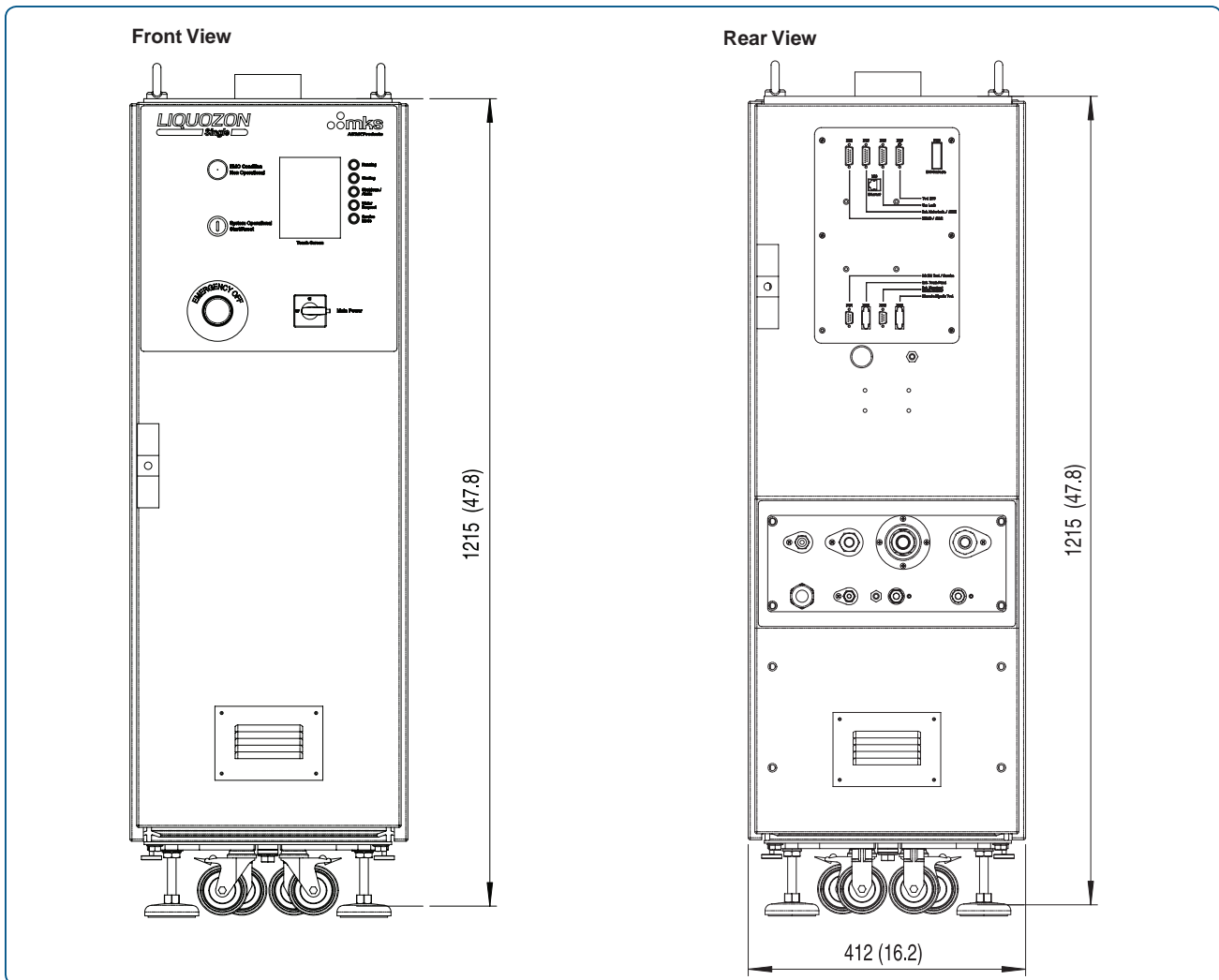

Dimensional Drawings —

Note: Unless otherwise specified, dimensions are nominal values in millimeters (inches referenced).



Specifications and Ordering Information

Performance			
Specified Maximum Dissolved Ozone Concentration @ UPW Flow Rate (at 20°C)			
LIQUOZON Single Version and Ordering Part #:	14-0041-222	14-0042-222	14-0044-222
System Pressure	2.5 bar _{gauge} (36 psig)	2.5 bar _{gauge} (36 psig)	2.5 bar _{gauge} (36 psig)
@ DIO ₃ Flow Rate of:			
at 2 L/min	55 ppm	75 ppm	95 ppm
at 5 L/min	35 ppm	50 ppm	70 ppm
at 10 L/min	20 ppm	35 ppm	50 ppm
at 20 L/min	—	15 ppm	30 ppm
Operating Range			
Flow	0.5 – 10 L/min	0.5 – 20 L/min	0.5 – 20 L/min
Operating Pressure	Constant set point configurable from 1.0 to 2.5 bar _{gauge} (15 -36 psig), closed-loop controlled, nominal pressure 2.5 bar _{gauge} (36 psig)		
Facility Requirements			
	14-0041-222	14-0042-222	14-0044-222
Ambient Temperature	Max 35°C (95°F)		
Feed Gas O₂			
Quality	Oxygen, Grade 4 (purity > 99.995%) or better		
Inlet pressure	4.5 – 7.6 bar _{gauge} (65 -110 psig)		
Flow Rate	Typically 1.4 slm	Typically 2.8 slm	Typically 5.6 slm
Dopant Gas CO₂			
Quality	Carbon Dioxide CO ₂ , grade 4.5 (purity > 99.995%) or better		
Inlet pressure	5.0 – 7.6 bar _{gauge} (73 -110 psig)		
Flow Rate	Typically 0.15 slm		
Ultra Pure Water UPW			
Pressure	1.8 – 5.0 bar _{gauge} (26 – 73 psig), min 0.8 bar (12 psi) above system operating pressure		
Purity	Purity according to process demands		
Temperature	15 - 25°C (59 - 77°F)		
Cooling Water			
Quality	Demineralized (Resistivity > 50 kΩ cm), 100 μm filtered		
Recommended Flow	Typically 1.5 L/min (0.4 gpm)	Typically 2.3 L/min (0.61 gpm)	Typically 3.7 L/min (0.98 gpm)
Temperature	17 – 23 °C (63 – 73 °F), rated 20°C (68 °F)		
Pressure	2.0 – 5.0 bar _{gauge} (29 - 73 psig)		
Compliance			
	CE, SEMI S2-0302, SEMI F47, SEMI S2, UL 61010-1		
Power	3/PE-, 208 VAC, 50/60 Hz, 0.500 kVA	3/PE-, 208 VAC, 50/60 Hz, 0.850 kVA	3/PE-, 208 VAC, 50/60 Hz, 1.600 kVA
Control Interfaces	Discrete communication, RS232		
Physical Data			
Weight	Approx. 135 kg (298 lbs.)		
Dimensions	412 x 512 x 1215 mm (16.2" x 20.2" x 47.8")		

Please contact your local MKS sales office for price and availability information.



MKS Instruments, Inc. Global Headquarters

2 Tech Drive, Suite 201
Andover, MA 01810
Tel: 978.645.5500
Tel: 800.227.8766 (in USA)
Web: www.mksinst.com

MKS Instruments, Inc. Plasma & Reactive Gas Solutions

90 Industrial Way
Wilmington, MA 01887
Tel: 978.284.4000

MKS Instruments Deutschland GmbH Plasma & Reactive Gas Solutions

Wattstr. 11-13
13355 Berlin, Germany
Tel: +49.30.464.0030