

GE250A

Elastomer Sealed, Digital Mass Flow Controller
Flow Rates Up to 250 SLM



The GE250A is a general purpose, elastomer sealed MFC well suited for a wide variety of applications requiring flow control capability from 100 slm to 250 slm Full Scale, N₂ equivalent. The GE250A incorporates the latest in digital flow control electronics along with a well proven, patented thermal sensor and mechanical design. This MFC is available with either analog or digital I/O. The digital control electronics utilize the latest in MKS control algorithms provide fast and repeatable response to set point.

Settling times of 1 to 2 seconds and set point accuracies below 1% of set point outperform those of other typical high flow MFCs. Precise control is maintained down to 2% of the GE250A configured Full Scale flow range. The multi-gas/multi-range capability, along with tight performance specifications for accuracy, control range, and transient response allow users to minimize inventory of high flow MFC part numbers.

The multi-gas/multi-range feature (along with other custom controls) is accessed through the MFCs embedded diagnostic interface, which requires no special software or hardware to operate. A standard Ethernet cable and JAVA-enabled HTML browser, widely available, are all the tools needed. The critical gas parameters for typical high flow rate gases are already stored on the device. Configuring the device is simply a matter of selecting the gas from a drop down menu and specifying the desired full scale flow range. The diagnostic interface also allows the user to perform routine device health checks, plot flow response, and store operating data for off-line analysis.

Product Features

- Fast response to set point change reduces flow stabilization time for short process steps, enhancing process throughput
- Tightly controlled flow accuracy of process gas enables improved process matching
- Reduced inlet pressure (pressure drop) requirement simplifies gas supply regulation from a single source
- Reduces MFC inventory through its multi-gas/multi-range capability
- Accurate flow control over a wide dynamic range, even when down ranged, reduces need for an additional low range MFC



Key Benefits

- Device configuration and diagnostics made simple through standard Ethernet interface
- Uses a standard web browser with no special software required

Specifications

Performance

Full Scale Range (N ₂ equivalent)	100 to 250 slm
Maximum Inlet Pressure MFC/MFM	150 psig (can not exceed pressure differential requirement across MFC)
Normal Operating Pressure Differential (with atmospheric pressure at the MFC outlet)	30 to 55 psid (dependent on fitting type)
Burst Pressure	1500 psig
Control Range	2% to 100% of Full Scale (range on mech.)
Typical Accuracy	±1% of set point for > 20% to 100% Full Scale ±0.25% of Full Scale for 5% to 20% Full Scale
Repeatability	±0.5% of Reading
Resolution	0.1% of Full Scale
Temperature Coefficients Zero Span	<ul style="list-style-type: none"> • <0.05% of Full Scale/°C • <0.08% of Reading/°C
Inlet Pressure Coefficient	<0.03% of Reading/psi or less
Typical Controller Settling Time	1 to 2 seconds typical above 10% Full Scale @ 50 psi
Warm-up Time	1 hour
Operating Temperature Range (Ambient)	10°C to 50°C
Storage Humidity	0 to 95% relative humidity, non-condensing
Storage Temperature	-20° to 65°C (-4° to 149° F)

Mechanical

Fittings (compatible with)	8 VCO® male, ½" NPT female, ½" Compression, 8 VCR® male, 12 mm Swagelok, ⅜" Swagelok, W-seal, ½" Compression Long, 8 VCR Male Long, 8 VCO Male Long
Leak Integrity External (scc/sec He) Through Closed Valve	<ul style="list-style-type: none"> • <1 x 10⁻⁹ • < 1.0% Full Scale at 40 psia to vac (<500 mTorr) (To assure no flow-through, a separate positive shut-off valve is required.)
Wetted Materials	316L S.S. 17-7 S.S., Elgiloy®, 430FR
Seal Options	<ul style="list-style-type: none"> • Viton® • Buna • Neoprene® • EPDM • Viton (USP Class VI Compliant)
Surface Finish MFC/MFM	16μ inch average Ra
Weight	<4.5 lbs (2.05 kg)

Electrical Analog I/O

Input Power Required	+15 to +24 VDC @ (<4 watts)
Flow Input/Output Signal Voltage (0 to 5 VDC) Current (4 to 20 mA)	<ul style="list-style-type: none"> • 15 pin Type "D" male • 15 pin Type "D" male
Compliance	CE

Digital I/O	DeviceNet™	RS485	Profibus®	EtherCAT®	PROFINET®
Input Power Required	+11 to +25 VDC per (<4 watts)	+15 to +24 VDC (<4 watts)	+15 to +24 VDC (<4 watts)	+24 VDC (<5 watts)	+24 VDC (<5 watts)
Connector	5 pin micro connector (power and comm.)	9 pin Type D male (power and comm.)	9 pin Type D male (power) 9 pin Type D female (comm.)	2 x RJ-45 (comm.) male, M8 male, 5 pin (power)	2 x RJ-45 (comm.) male, M8 male, 5 pin (power)
Data Rate Switch/Selection	4 positions: 125, 250, 500K (Default), (programmable over network)	No switch Set data rate via RS485	No switch Set data rate via Profibus	No switch	No switch
Comm. Rate(s)	125 Kbps; 250 Kbps; 500 Kbps	9.6 Kbps; 19.2 Kbps 38.4 Kbps	9.6 Kbps to 12 Mbps	100 Mbps	100 Mbps
MAC ID Switches/Addresses	2 switches, 10 positions; 0,0 to 6,3 1 to 254	Set address over RS485 Station Addresses 0,0 to 9,9	2 switches, 10 positions	3 switches, 16 positions	N/A
Network Size	Up to 64 nodes	Up to 32 nodes	Up to 99 nodes	Up to 4095 nodes	N/A
Visual Indicators	LED Network (green/red) LED Module (green/red)	LED Comm (yellow) LED Error (red)	LED Comm (green/red) LED Error (green/red)	LED Power (green) LED Run (green) LED Error (red) LED Comm (green)	LED Maint (amber) LED BUS Fault (red) LED Ready (green) LED Sys Fault (red)
Compliance	CE	CE	CE	CE	CE

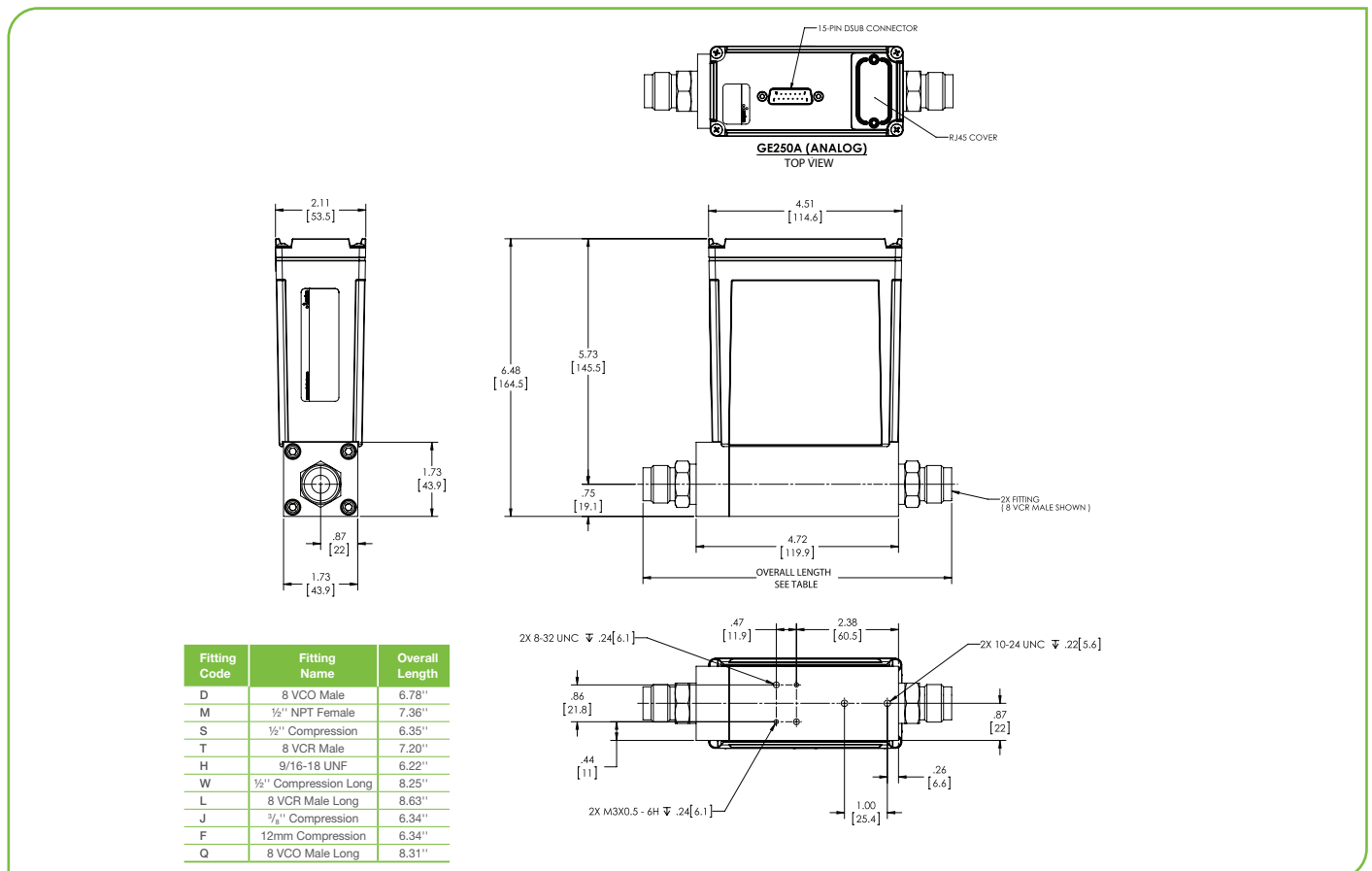

Unless otherwise specified, dimensions are nominal values in inches (mm referenced). *See manual for additional I/O and fitting types.

Ordering Information

Ordering Code Example: GE250A013255TBV0020				Code	Configuration
Model					
MFC High Flow Mass Flow Controller (multi-gas, multi-range)				GE250A	GE250A
Gas*					
Name	Code	Formula	Min/Max Full Scale (slm)		
Helium	001	He	140 to 350	001	013
Argon	004	Ar	140 to 250	004	
Hydrogen	007	H ₂	100 to 250	007	
Air	008	Air	100 to 250	008	
Nitrogen	013	N ₂	100 to 250	013	
Flow Range Full Scale**					
250 slm (250,000 sccm)				255	255
Fittings (compatible with)					
12 mm Swagelok				F	T
3/8" Swagelok				J	
1/2" tube compression				S	
1/2" Compression Long				W	
1/2" NPT female				M	
8 VCR Male				T	
8 VCO Male				D	
8 VCR Male Long				L	
8 VCO Male Long				Q	
W-Seal				H	
Connector (Power & Control I/O)					
Profibus (1179B Compatible)				3	B
Profibus (1480 Compatible)				4	
RS485				5	
DeviceNet				6	
EtherCAT				8	
PROFINET				9	
15 pin D (Analog 0 to 5 VDC I/O)				B	
15 pin D (4 to 20 mA I/O)				H	
Seal Material					
Viton				V	V
Buna				B	
Neoprene				N	
EPDM				E	
Viton (USP Class VI Compliant)				W	
Valve/Device Type					
Normally Closed				0	0
Mass Flow Meter				3	
Reserved for MKS Future Use					
Standard				0	0
Firmware					
Unless otherwise specified, MKS will ship firmware revision current to date.				20	20

* For gases not listed in the standard products gas table, please contact the MKS applications department for assistance.

** The Full Scale flow rate is designated by a 3 digit number. The first two digits represent the significant digits of the Full Scale flow rate separated by a decimal point. The third digit is the exponent of the power of ten. Example flow rate code: 255 is 2.5 x 10⁵ sccm or 250 slm; 105 is 1.0 x 10⁵ sccm or 100 slm