



971B UniMag™  
Vacuum Pressure Transducer  
**RS232 / RS485 / Display**  
**Operation and Installation Manual**

P/N: 100017129  
971B UniMag™ Transducer  
Operation and Installation Manual  
Revision: J, February 2020

---

## Notice

**This product is intended for use by industrial customers and should be serviced only by MKS trained representatives. The service manuals and related materials are provided in English at no charge and are intended for use by experienced technicians. It is the responsibility of the user to obtain and assure the accuracy of any needed translations of manuals. If you require assistance, contact the MKS Customer Service group. The MKS Technical Support Group notifies users of record if safety-related upgrades or new hazards associated with the product are identified.**

### Damage Requiring Service

Disconnect the product from all power sources and refer servicing to Qualified Service Personnel under the following conditions:

- a. When any cable or plug is damaged.
- b. If any liquid has been spilled onto, or objects have fallen into the product.
- c. If the product has been exposed to rain or water.
- d. If the product does not operate normally even if you follow the operating instructions. Adjust only those controls that are covered by the operation instructions. Improper adjustment of other controls may result in damage and will often require extensive work by a qualified technician to restore the product to its normal operation.
- e. If the product has been dropped or the enclosure has been damaged.
- f. When the product exhibits a distinct change in performance. This indicates a need for service.

### Service and Warranty

Some minor problems are readily corrected on site. If the product requires service, contact the MKS Technical Support Department at +1-833-986-1686. If the product must be returned to the factory for service, request a Return Material Authorization (RMA) from MKS. Do not return products without first obtaining an RMA. In some cases, a hazardous materials disclosure form may be required. The MKS Customer Service Representative will advise you if the hazardous materials document is required.

When returning products to MKS, be sure to package the products to prevent shipping damage. Shipping damage on returned products due to inadequate packaging is the Buyer's responsibility.

#### **Customer Service / Technical Support:**

MKS Global Headquarters  
2 Tech Drive, Suite 201  
Andover MA, 01810 USA  
Phone: +1-833-986-1686  
Email: [insidesales@mksinst.com](mailto:insidesales@mksinst.com)  
Visit our website at: [www.mksinst.com](http://www.mksinst.com)

### Warranty Information

MKS Instruments, Inc. provides an eighteen (18) month warranty from the date of shipment for new MKS products. The MKS Instruments, Inc. general terms and conditions of sale provide the complete and exclusive warranty for MKS products. This document is located on our web site at [www.mksinst.com](http://www.mksinst.com), or may be obtained by a contacting an MKS customer service representative.

---

## Proprietary Information

This document contains confidential proprietary information belonging to MKS Instruments, Inc. This information is not for publication and has been provided to MKS on the condition that it not be copied, reproduced or disclosed, either wholly or in part, to third parties without the expressed written consent of MKS Instruments, Inc.

The information contained in this document is subject to change without notice.

## Copyright Information

© 2020 MKS Instruments, Inc. All rights reserved. Granville-Phillips® is a registered trademark of MKS Instruments, Inc., and mksinst™, DualTrans™, MicroPirani™, UniMag™, DualMag™, TriMag™, and QuadMag™ are trademarks of MKS Instruments Inc. Windows® is a trademark of Microsoft Corporation. All other trademarks and registered trademarks are the properties of their respective owners.

No part of this work may be reproduced by any method including photocopying and recording or by any information or retrieval system without written permission of MKS Instruments, Inc.

## Table of Contents

Proprietary Information.....	3
Copyright Information.....	3
Table of Contents.....	3
Safety Information.....	4
Symbols used.....	4
Safety Precautions.....	4
Unpacking.....	5
Description.....	6
971B Functions.....	7
LED Status Indicator.....	7
Transducer Installation (Mechanical).....	8
Transducer Installation (Electrical).....	9
Serial user interface.....	11
Communication Protocol.....	12
Setpoint relays.....	14
Integrated Touch Display.....	16
Cold Cathode Sensor Control.....	18
Calibration and Adjustment.....	21
Factory Defaults.....	22
Resetting to factory default.....	22
Transducer Lock Function.....	23
Status Query Commands.....	24
Analog Output.....	25
Analog output setup.....	26
Query Command List.....	30
Setup and configuration command list.....	31
FAQ (Frequently Asked Questions).....	32
Troubleshooting.....	34
Service and Repair.....	35
Specifications.....	36
Accessories and Replacement Parts.....	39
PDR 900 Display and Power Supply.....	40
Index.....	41

---

## Safety Information

### Symbols used

The first symbol below is used throughout this manual to further define the safety concerns associated with the product. The last two symbols identify other information in this manual that is essential or useful in achieving optimal performance from the 971B UniMag transducer.

---

**Caution:**



**Refer to manual.** Failure to read message could result in personal injury or serious damage to the equipment or both.

---

**Critical:**



Failure to read message could result in damage to the equipment.

---

**Attention:**



Calls attention to important procedures, practices or conditions.

---

### General safety information

The safety instructions should always be followed during installation and operation of the 971B UniMag transducer. Pass safety information to all users.

### Safety Precautions



**Electrical connections.** The 971B must be properly electrically connected in order to perform according to the specifications. Output pins are not protected against wrong electrical connections. Wrong electrical connections can cause permanent damage to the transducer or interference to measuring performance. Refer to Electrical connections description page 7.



**Fuse.** The 971B power supply input has an internal thermal fuse. The fuse is self recoverable and should not be changed.



**Explosive Environments.** Do not use the 971B in presence of flammable gases or other explosive environments.

**Corrosive Environments.** The 971B is not intended for use in corrosive environments. Refer to Transducer installation page 6.

---

**Service and Repair.** Do not substitute parts or modify instrument other than described in Service and Repair page 32. Do not install substituted parts or perform any unauthorized modification to the instrument. Return the instrument to a MKS Calibration and Service Center for service and repair to ensure all of the safety features are maintained.

---

**Magnetic interference.** The 971B contains a permanent magnet that can interfere with performance and operation of other electronics equipment and life support devices like pacemakers. Only install the 971B where it cannot interfere with other electronics.



**CE Mark:** The 971B transducer complies with European standards for CE marking.



# Unpacking

Before unpacking your 971B UniMag transducer, check all surfaces of the packing material for shipping damage. Inspect for visible damage. If found, notify the carrier immediately. Please be sure that your 971B package contains these items:

Part number	Description
971B-xxxxx	971B Transducer
100017130	Short form manual
100017096	Documentation & Software CD

If any items are missing, call MKS Customer Service at +1-833-986-1686 or your local MKS sales office or distributor.

## Part Number

The 971B UniMag part number system has 5 digits that identify flange, communication interface, analog output type, I/O connector and sensor sealing type. Transducers can be delivered with customer configuration of various parameters like setpoint settings and these specials have additional 4 digits after the regular part number.

	Flange	Interface	Analog out	Connector Relays	Enclosure sealing
971B-	1	1	0	2	0
					0 Standard / viton sealing
					2 SUBD 15pinHD male / no relay 3 SUBD 15pinHD male / 3 relays 5 SUBD 15pinHD male / 3 relays / Dual Aout 8 RJ45/FCC68 8 pin (Edwards type) 9 Hirschmann 6 pin (Pfeiffer / Inficon type)
					0 Standard mks 1 Edwards APG-L 3 Edwards WRG 5 Inficon MPG400 / Pfeiffer PKR251 6 Inficon BPG400 (999 DAC2)
					1 RS232 / Analog 2 RS485 / Analog
					0 Custom 2 KF25 7 CF2.75 9 KF40

## Special versions

Part number  
 971B-x1090-0001 Pfeiffer IKR251 pin and output compatible  
 971B-x1080-0002 Edwards AIM-S pin and output compatible  
 971B-x1080-0003 Edwards AIM-X pin and output compatible

## Description

The 971B UniMag™ vacuum transducer offers a wide measuring range from  $1 \times 10^{-8}$  to  $5 \times 10^{-3}$  Torr and is based on measurement of cold cathode ionization current.



The 971B is designed for general purpose pressure measurement and control as a standalone unit or with the PDR900 display and controller unit. The transducer uses RS232 or RS485 digital communication interface for setup of transducer parameters and to provide real time pressure measurement.



The 971B has up to three mechanical relays which can be used for process control, for example interlocking valves or pumps. The analog voltage output can be interfaced to external analog equipment for pressure readout or control.

### Sensor technology

The cold cathode inverted magnetron utilizes a high voltage anode, cathode and a permanent magnet. Electrons are accelerated towards the anode and will ionize molecules by collision. The magnetic field deflects the electrons, causing them to spiral as they move across the magnetic field to the anode. This spiraling movement increases the opportunity for them to encounter and ionize the molecules. The ionization of the molecules creates an electric current as a function of the pressure.

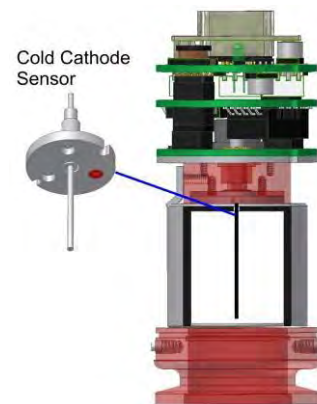

### Applications

The 971B can be used in many different vacuum applications within the semiconductor, analytical and coating industries:

- General vacuum pressure measurement
- Coating
- Mass spectrometer control
- System process control
- Sense abnormal pressure and take appropriate security measures using set point relays
- Control system base pressure

### Disposal (European Union only)

The 971B transducer is manufactured according to the RoHS directive.



For the benefit of the environment, at the end of life of the 971B, it should not be disposed in the normal unsorted waste stream. It should be deposited at an appropriate collection point or facility to enable recovery or recycling.



## 971B Functions

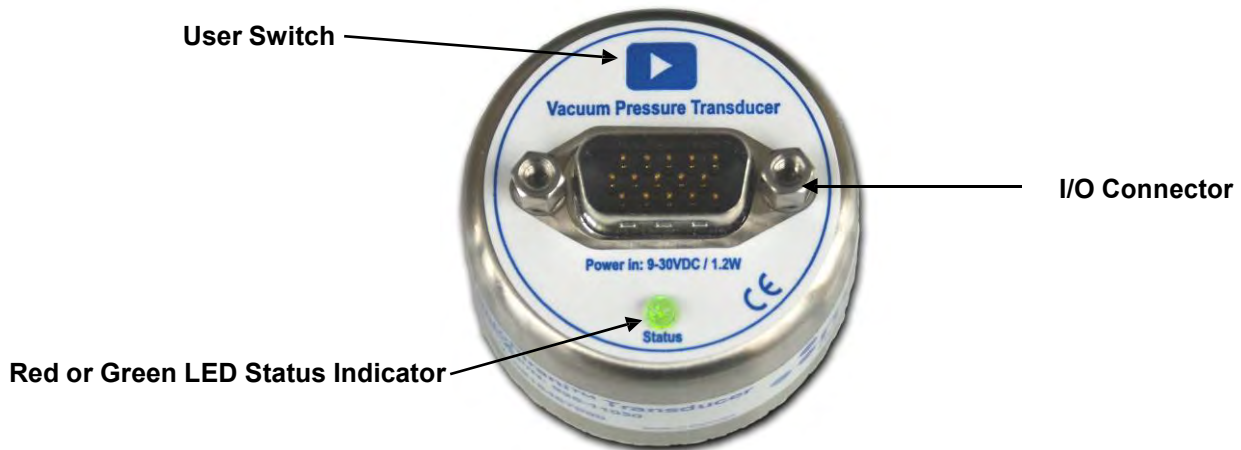

### User Switch

The user switch turns ON the cold cathode sensor.

Refer to page 18 for operation procedure.



The cold cathode sensor should only be turned on when vacuum pressure is below  $5 \times 10^{-3}$  Torr



If the transducer is delivered with customer specified parameters, the User Switch is disabled. For enabling the switch see page 22.

### LED Status Indicator

The red/green LED status indicator has the following stages:

- |                               |  |
|-------------------------------|--|
| 1. GREEN                      | Normal operation   |
| 2. 2 sec. RED                 | Power on sequence  |
| 3. GREEN 1 sec. flash cycle   | Test mode TST!ON (see page 23)                                       |
| 4. GREEN 0.5 sec. flash cycle | Cold Cathode high voltage turned on                                  |
| 5. Red 0.5 sec. flash cycle   | Cold Cathode high voltage turned on, but ionization has not started. |
| 6. RED                        | Sensor failure (see page 34)   |
| 7. OFF                        | Power off  |

## Transducer Installation (Mechanical)



**Do not use or install the 971B transducer where the following conditions occur:**

- Temperatures lower than 0 °C or higher than 40 °C
- Corrosive or explosive gases
- Direct sunlight or other heat sources
- Magnetic fields

### Process compatibility

The 971B transducer is intended for use in relatively clean environments.

If the 971B transducer is located close to a gas source connection like a flow controller or leak valve the transducer pressure measurement can be higher than the actual chamber pressure. Location close to a pumping system connection can cause a lower pressure measurement than actual chamber pressure.

The 971B transducer and its sensor design can be mounted in any orientation without compromising accuracy.

### Explosive Environments

The 971B should not be used in explosive environments, due to its high voltage potential that can cause ignition.

### Temperature

For best measuring performance avoid large temperature gradients and direct cooling like air-condition air stream or direct heating like a pump exhaust stream.

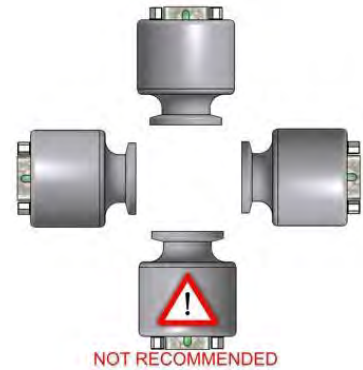

### Bake out

The transducer electronics can withstand 80 °C (176 °F) when the power is turned off.

### Contamination

Locate and orient the 971B where contamination is least likely.



If the transducer is backfilled with a liquid (like pump oil) the sensor can be cleaned. Refer to Service and Maintenance page 35.

### Vacuum connections

The 971B transducer is available with different types of vacuum fittings. When mounting the transducer always ensure that all vacuum sealing items and surfaces are clean, without damage and free of particles. Do not touch the vacuum flange sealing surface.



If the transducer will be exposed to pressures above atmospheric pressure, make sure that proper vacuum fittings are used. Ensure that the internal system pressure is at ambient pressure conditions before opening the vacuum system and removing any connections.

### Pressure range

The standard 971B transducer is internally sealed with elastomer viton sealing for use down to  $1 \times 10^{-8}$  Torr. The 971B can be exposed to positive pressure up to 3000 Torr absolute.



## Transducer Installation (Electrical)

The 971B is available with different input/output connectors. Use a cable with strain relief to ensure proper electrical connection and to reduce stress on the connectors.



**Ensure a low impedance electrical connection between the 971B transducer body and the grounded vacuum system to shield the sensor from external electromagnetic sources.**

**Ensure that the analog output is connected to a floating input.**

To comply with EN61326-1 immunity requirements, use a braided shielded cable. Connect the braid to the metal hoods at both ends of the cable with the end for power supply connected to earth ground.

The power supply input is 9 to 30 VDC. The power supply input is protected by an internal thermal fuse. The fuse is self-recoverable; do not replace it. Damage may occur to the circuitry if excessive voltage is applied, polarity reversed or if a wrong connection is made.

If using the analog voltage output, connect the positive analog out and negative analog out pins to a differential input voltmeter or an analog-to-digital (A/D) converter. Do not connect the negative side of the analog output to the negative side of the power supply input or to any other ground. Doing so will cause half of the power current to flow through this wire. Measurement errors in the output voltage may be seen due to the voltage drop from this current. The longer the cable, the worse the error will be. Do not connect the set point relay terminals to the analog output.

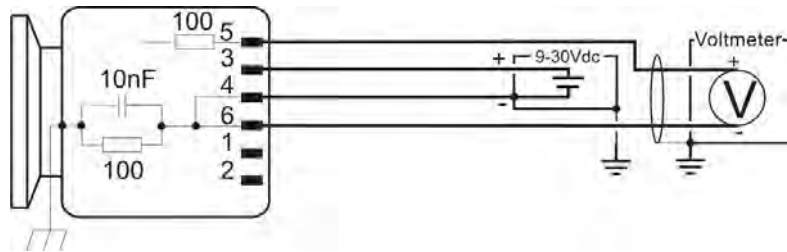

*Correct connection of analog output to floating input*

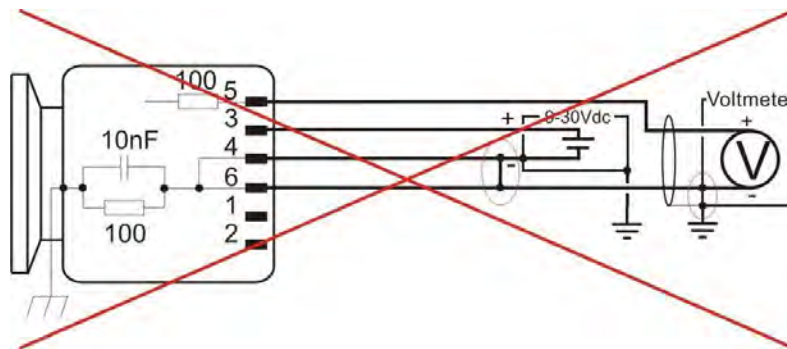

*Incorrect connection of analog output to none floating input*

### High Voltage Control

The 971BUniMag must be controlled externally to ensure that the high voltage is not enabled at pressures higher than  $5 \times 10^{-3}$  Torr. The protect setpoint feature prevents continuously operation at high pressures, however it should not be used as control function for the high voltage.

Refer to pages 18 through 20 for control options.



Continuously operation over  $5 \times 10^{-3}$  Torr and fast pressure spikes with the high voltage enabled can damage the cold cathode sensor element or cause shift in calibration.

## Input/Output Wiring

### 971B I/O Connector (15 pin)

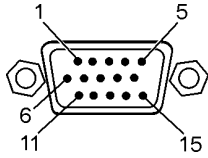

15 pin male HD DSUB

PIN	Description
1	RS485- / RS232 Transmit
2	RS485+ / RS232 Receive
3	Power + (9-30 VDC)
4	Power return -
5	Analog Output +
6	Analog Output -
7	Relay 1, Normally Open <sup>(1)</sup>
8	Relay 1, Common <sup>(1)</sup>
9	Relay 1, Normally Closed <sup>(1)</sup>
10	Relay 2, Normally Closed <sup>(1)</sup>
11	Relay 2, Common <sup>(1)</sup>
12	Relay 2, Normally Open <sup>(1)</sup>
13	Cold cathode enable (Active low)
14	Relay 3, Common <sup>(1)</sup>
15	Relay 3, Normally Open <sup>(1)</sup>

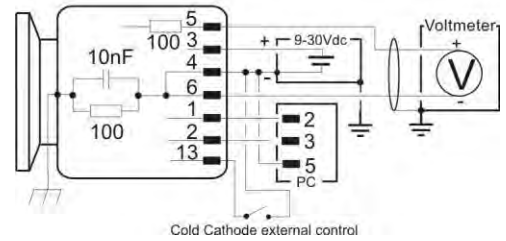

(1) Relays are optional (See part number page 3)



**Cold cathode external control pin 13 must be floating or shorted to power supply ground pin 4. Do not connect to a voltage source. Connection to voltage source can cause permanent damage to the transducer.**

### 971B I/O Connector P/N: 971B-x1090-0001 (6 pin Hirschmann)

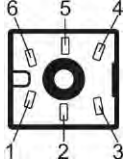

PIN	Description
1	Identification resistor (5.1KΩ)
2	Analog Output +
3	Analog Output -
4	Power + (9-30 VDC)
5	Power return -
6	Chassis

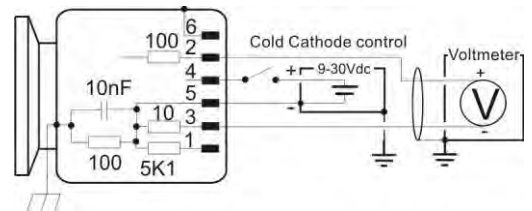

P/N: 971B-x1090-0001, will always enable the high voltage when power is turned on. Power supply must be external controlled by switching power (pin 4) on and off to avoid continuously operation at high pressure.

### 971B I/O Connector P/N: 971B-x1080-0002 P/N: 971B-x1080-0003 (8 pin RJ45/FCC68)

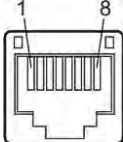

PIN	Description
1	Power + (9-30 VDC)
2	Power return -
3	Analog Output +
4	Identification resistor <sup>(2)</sup>
5	Analog Output -
6	Set point output (Open collector)
7	Cold cathode enable (Active low)
8	Not Connected

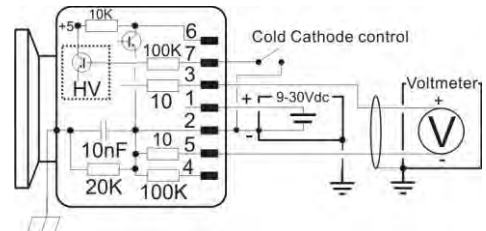

(2) Resistor value: 971B-x1080-0002: 100K, 971B-x1080-0003: 110K

### 971B RS232 connector (6 pin Hirschmann + 8 pin RJ45/FCC68)

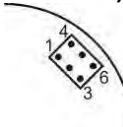

PIN	Description
1	RS232 Transmit
2	RS232 Ground
3	RS232 Receive
4	RS232 Receive
5	RS232 Ground
6	RS232 Transmit

## Serial user interface

The 971B is as standard supplied with RS232 or RS485 user interface. The user interface allows change of transducer parameters such as set point settings and calibration.

The serial interface uses the following data format: 8 data bits, 1 stop bit and no parity bit.

### RS232 user interface

The 971B is DCE (Data Communication Equipment) and can be connected to DTE (Data Terminal Equipment), typically a PC.

The serial communication does not use hardware handshake. The RS232 standard does not specify the maximum cable length, but length depends on environment, cable quality and communication speed. In general cable spans shorter than 15m (50ft.) do not require any extra precautions.

The RS232 connection on transducers delivered with 6 pin Hirschmann and 8 pin RJ45/FCC68 connector is available at a separate connector. Refer to Accessories and Replacement part number page 36 for RS232 programming cable. The connector is located under the label on the top of the transducer.

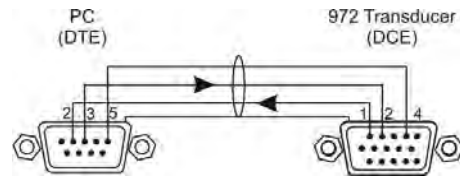

### RS485 user interface

RS485 is a network communication system that enables the user to communicate with several units on the same communication line.

RS485 is a balanced communication system, because signal on one wire is ideally the exact opposite of the signal on the second wire. Compared to RS232 communication RS485 allows significantly longer cable span. The maximum length of cable span depends on the environment, cable quality and communication speed, but relative long cable spans up to 1,200m (4,000 ft.) is possible.

There are 2 wires other than ground that are used to transmit the digital RS485 signal. The 971B uses half duplex communication.

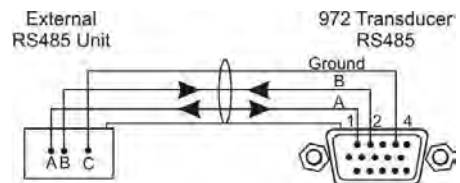

**Always use high quality shielded data cables for serial communication. For long cable runs use twisted pairs. See also Accessory and Replacement part number page 36.**

The EIA-485 and NMEA standards specification states that signal A is the inverting “-“and signal B is the non-inverting or “+”. This is in conflict with the A/B naming used by a number of differential transceiver manufacturers which is incorrect, but their practice is used throughout the industry. Therefore, care must be taken when using A/B naming. In addition to the A and B connections, the EIA standard also specifies a third interconnection point called C, which is the common ground.

At high communication baud rates and when using long cable runs, a termination resistor of typical 120 Ohm should be connected between pin 1 and 2 at the 971B DSUB connector and between pin A and B at the data communication equipment. The termination resistors provide low impedance that reduces the sensitivity to electrical noise and prevents data reflection that can cause data communication corruption.

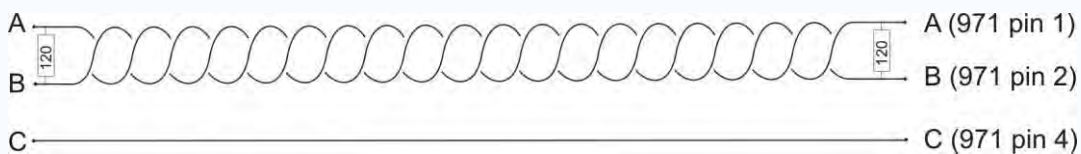

*RS485 twisted pair cable run with 120  $\Omega$  terminator resistors (971B with 15 pin connector)*



When connecting multiple devices in a RS485 network make sure that proper guidelines and specifications are followed to ensure optimal communication performance of the 971B. Improper network design can cause data communication interruption and data collision.

# Communication Protocol

The 971B transducer command set allows the user to change transducer parameters and receive pressure measurements. Settings and parameters like set point values, set point configurations and calibration data are stored in the transducers non-volatile memory.

### Communication software

Communication software is required to communicate from PC via RS232/485 interface to the transducer. In the standard Microsoft Windows package, the hyper terminal software can be used to type and transmit serial commands to the transducer. To the right is illustrated the Windows communication port properties for communicating with transducer factory default settings. MKS also offers communication software examples that can be downloaded at: [www.mksinst.com/vtsw/](http://www.mksinst.com/vtsw/)

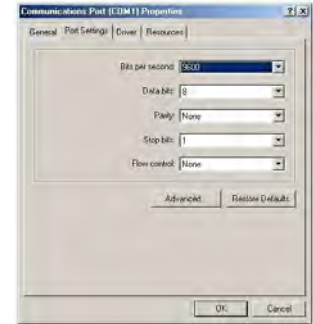

In OEM applications transducer communication software routines are normally integrated with other system control software.

### Query and Command Syntax

Queries return current parameter settings; commands change the parameter setting according to the value the user enters into the command syntax. Each query or command must begin with the attention character @ and end with the termination ;FF.

Command syntax for an information query:

@<device address><query>;FF

Command syntax for a command:

@<device address><command>!<parameter>;FF

The command set allows upper and lower case ASCII characters.

### Response Syntax (ACK/NAK)

The ASCII characters 'ACK' or 'NAK' preface the query or command response string. The ACK sequence signifies the message was processed successfully. The NAK sequence indicates there was an error.

The response to a query or a successful command is:

@<device address>ACK<data>;FF

The response to a message with an error is:

@<device address>NAK<NAK code>;FF

Examples:

ACK response: @253ACK9600;FF (baud rate changed to 9600)

NAK response: @253NAK160;FF (command had an error—possible typo)

The following list provides descriptions of the NAK codes that may be returned.

NAK Code	Error description	Example
8	Zero adjustment at too high pressure	@253VAC!;FF
9	Atmospheric adjustment at too low pressure	@253ATM!7.60;FF
160	Unrecognized message	@253S%;FF
169	Invalid argument	@253EN1!of;FF
172	Value out of range	@253SP1!5.00E+9;FF
175	Command/query character invalid	@253FV!;FF
180	Not in setup mode (locked)	-

---

## Baud rate

The baud rate represents the communication speed. The 971B supports 4800, 9600, 19200, 38400, 57600, 115200 and 230400 baud rates. The transducer is always delivered with 9600 bps factory default baud rate.

Change of Baud rate:

Command:	@253BR!19200;FF
Command values:	4800, 9600, 19200, 38400, 57600, 115200, 230400
Command reply:	@253ACK19200;FF
Factory default:	9600

The transducer will reply in the current baud rate and then change to the new value.

## Addressing

The transducer uses an addressable communication protocol that allows multiple MKS 900 Series transducer devices to be connected in a RS485 network. The address is required in both RS232 and RS485 communication.

The address can be set from 001 to 253. Address 254 and 255 are universal addresses, which can be used to broadcast a command to all devices on the network. Commands sent with address 254 will be executed by all transducers on the network and all transducers will transmit a reply. Commands sent with address 255 will be executed by all transducers on the network, but the transducers will not transmit replies. For example, use address 254 to communicate with a device if its address is unknown.

Change of Address:

Command:	@253AD!123;FF
Command values:	001 to 253
Command reply:	@253ACK123;FF
Query:	@254AD?;FF
Query reply:	@253ACK253;FF
Factory default:	253

## Communication delay (RS485)

The 971B half duplex RS485 interface requires that data is transmitted and received on the same communication line. Some RS485 transceiver equipment have a settling time when changing from transmit to receive mode. If the transducer replies too fast the first character(s) will not be received as the following example illustrates:

Sending pressure request:	@254PR1?;FF
Receiving data: .	23E-4;FF (Correct data: @253ACK1.23E-4;FF)

The RS delay introduces a baud rate dependent delay between receive and transmit sequence to prevent loss of data in the receiving string.

Communication delay:

Command:	@253RSD!ON;FF
Command values:	ON, OFF
Command reply:	@253ACKON;FF
Query:	@253RSD?;FF
Query reply:	@253ACKON;FF
Factory default:	ON

## Setpoint relays

The 971B can be ordered with 3 mechanical relays that can be used for controlling external process equipment. The relay has closing and breaking contacts and the contacts are rated 30 VDC, 1A resistive load.

If the transducer is supplied without setpoint relays, the setpoint commands can still be accessed. Refer to part number definition page 3 to verify if setpoint relays are included.

### Inductive relay load

Special precautions should be taken when driving inductive loads at the relay contact. When an inductive load like a solenoid is energized, the in-rush current is significant higher than the regular load current. In-rush currents exceeding the relay contact rating can cause reduction of relay contact life time or contact reliability. When a solenoid is de-energized, the collapsing magnetic field can cause significant voltage spikes. These spikes can couple capacitive from cable to cable and interfere with measuring electronics or transducer signal.



**Driving inductive loads via the setpoint relay contacts requires de-energizing spike protection. Inadequate protection can cause permanent damage to the transducer or interfere with the analog output signal. Always ensure that inductive inrush currents do not exceed relay contact rating.**

An arc suppression network as shown schematically to the right is recommended. The values of the capacitance C and the resistance R can be calculated by the following equations:

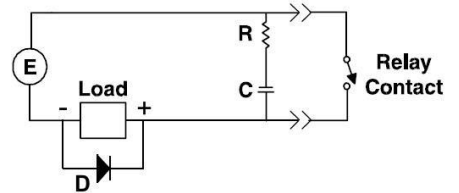

$$C = I^2 / (1 \times 10^7) \quad R = E / I^a$$

where:

C is in Farad. R is in Ohm

I is DC or AC<sub>peak</sub> load current in Ampere. E is DC or AC<sub>peak</sub> source voltage in Volt

$$a = 1 + (50/E)$$

Note that  $R_{\min} = 0.5 \Omega$  and  $C_{\min} = 1 \times 10^{-9} \text{ F}$ . D is a fast transient suppression diode.

### PDR900 controller relays

The PDR900 controller has power relays that can drive higher current loads and voltages than the transducer relays. If the transducer is used with the PDR900 controller refer to PDR900 manual for setup of relay output.



**Do not connect any external sources to the transducer relay pins when using it together with the PDR900 controller. Always use the PDR900 relay outputs.**

### Setpoint functionality

The set point relays can be activated either above or below the set point values. The graphs below show the different relays stages in either below or above configuration. The NC contact will always be closed in case of power failure.

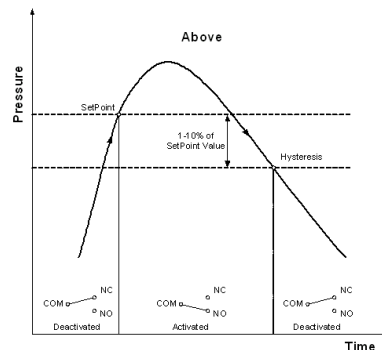
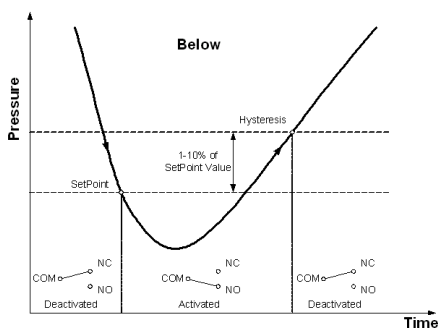



**When using the setpoint relay to control process equipment, always take appropriate precautions to prevent system damage in case of transducer power failure. The NC contact will be closed in case of transducer power failure.**



If the transducer is supplied as a special version (P/N: 97B1-xxxx-xxxx) with pre-configured parameters such as setpoint settings, the setup is per default locked. The transducer will reply with error code "NAK180" if the user tries to change parameters. To change pre-configured parameters refer to unlock procedure page 20.

### Setpoint setup by Serial interface

The correct procedure for setting up set point parameters are:

1. Enter set point value 5.00E-6 Torr  
Command: @253SP1!5.00E-6;FF Reply: @253ACK5.00E-6;FF
2. Select setpoint direction (ABOVE/BELOW)  
Command: @253SD1!BELOW;FF Reply: @253ACKBELOW;FF
3. Enter setpoint hysteresis value, if other than default +/- 10% of set point value is required.  
Command: @253SH1!6.00E-6;FF Reply: @253ACK6.00E-6;FF
4. Enable setpoint (OFF, ON)  
Command: @253EN1!ON;FF Reply: @253ACKON;FF

### Setpoint setup by PDR900 Controller

1. Edit > Setpoint > Setpoint 1> Setpoint Value 1  
Enter set point value 5.00E-6 Torr 

Enter pressure +5.00E-6 Torr
---------------------------------
2. Edit > Setpoint > Setpoint 1> Direction 1  
Select set point direction 

Direction 1 BELOW
----------------------
3. Edit > Setpoint > Setpoint 1> Hysteresis 1  
Enter set point hysteresis value  
Only if other than default +/- 10% of set point value is required. 

Enter pressure +6.00E-6 Torr
---------------------------------
4. Edit > Setpoint > Setpoint 1> Enable 1  
Enable set point 

Enable 1 ON
----------------

### Setpoint value

The setpoint value is the pressure either below or above which the setpoint relay will be energized.

### Setpoint hysteresis value

The hysteresis value is the pressure value at which the setpoint relay will be de-energized.

### Setpoint direction

The setpoint direction determines whether the relay is energized above or below the set point value.

### Enable setpoint

The enable setpoint command enables, disables or enable the setpoint relay.



**The 971B transducer has an auto hysteresis setting of 10% of the set point value that overwrites the current hysteresis value whenever the set point value or set point direction is changed. If other hysteresis value than 10% is required, first set the set point value and set point direction before setting hysteresis value.**

## Setpoint safety delay

The setpoint safety delay function requires 5 continuously measurements that exceeds setpoint value before the relay is tripped. This feature prevents that noise or pressure pulse can trig the relay. If fast setpoint response is required the setpoint safety delay can be disabled.

## Setpoint safety delay

Command: @253SPD!ON;FF  
 Command values: ON, OFF

Command reply: @253ACKON;FF  
 Query: @253SPD?;FF  
 Query reply: @253ACKON;FF  
 Factory default: ON

## Integrated Touch Display

For 971B transducer versions with integrated touch display it is possible to see information about setpoints, sensors, model, and measurements unit. A pressure threshold alarm can be set and for transmitters with multiple sensors, it is possible to choose which sensor pressure value is displayed on the screen. All of this is accessible by the following menu structure:

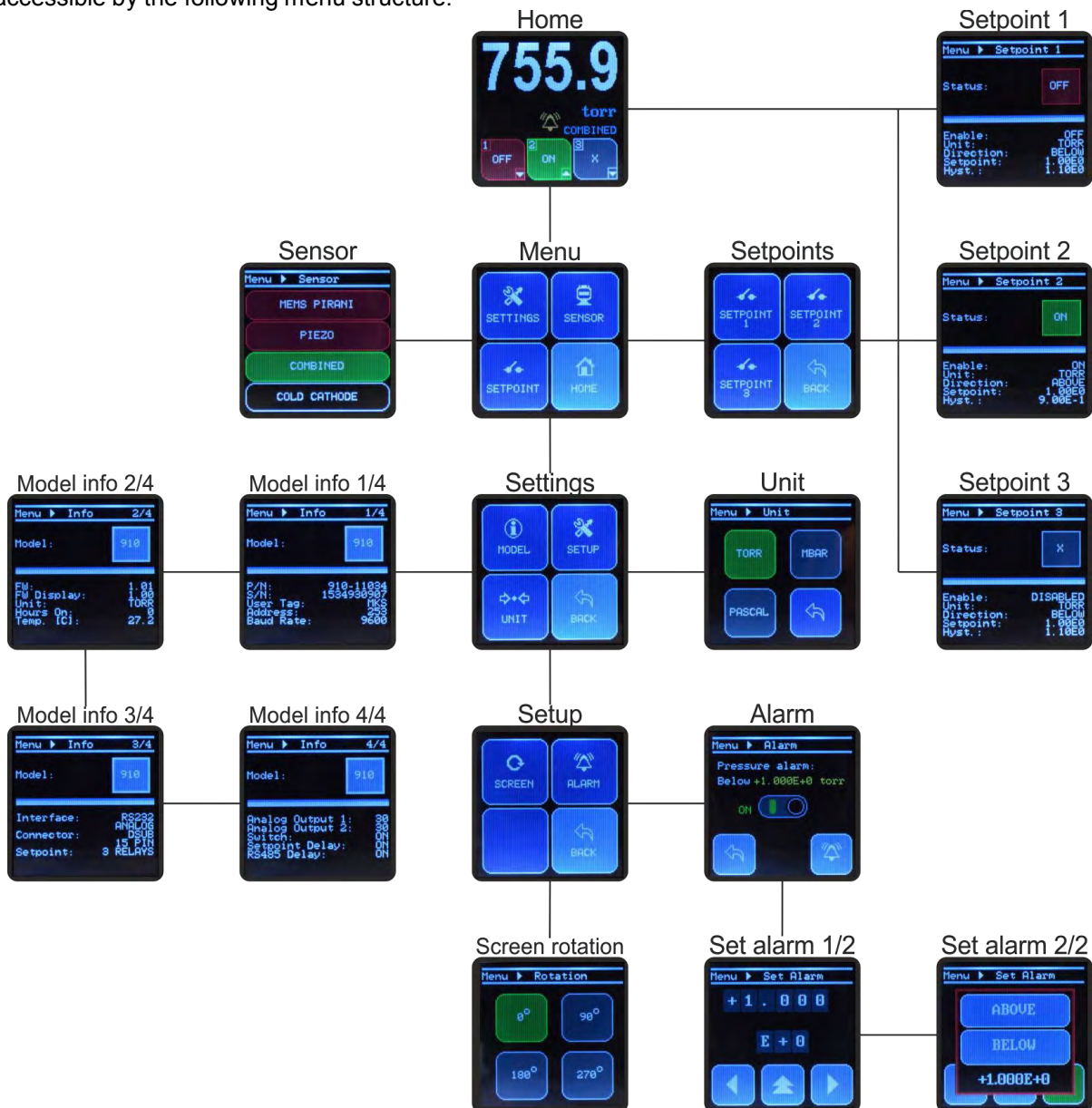



### Using the integrated touch display:

When the transducer is turned on, the initializing screen shows the transducer name while starting up. After start-up, the screen automatically switches to the Main screen. To access the Menu, push anywhere on the Main screen. The following table shows the different menus and options available:

Display-screen	Information		
Start-up	MKS logo and transducer model		
Home	The Home screen shows the current pressure, the transducer model, the status of the setpoints, the triggering direction of each setpoint and shows if an alarm is enabled. The setpoint buttons and unit text give quick access to the separate Setpoint-screens and Unit screen respectively.		
Menu	The general Menu contains 4 buttons which lead to: Settings, Sensor, Setpoints menu and Home.		
Settings	The Settings menu contains 4 buttons which lead to: Model info, Setup menu, Unit and Back		
Setup	The Setup menu contains 3 buttons which lead to: Screen rotation, Alarm and Back		
Sensor	The Sensor screen shows which sensor's measurement is displayed on the Home screen (green marked sensor).		
Setpoints menu	The Setpoint menu contains 4 buttons which lead to: Setpoint 1, Setpoint 2, Setpoint 3 and Back (to Menu)		
Setpoint screen	Setpoint 1,2 or 3		
	Each Setpoint screen shows the setpoint status, the pressure unit, pressure triggering direction, setpoint value and hysteresis value.		
	The setpoint status is indicated by:	X	Setpoint disabled (Grey)
		ON	Setpoint enabled ON (Green)
		OFF	Setpoint enabled OFF (Red)
	If the Setpoint screen is accessed via the Setpoint menu, pressing the screen will lead back to the same menu. If accessed via the quick-access buttons on the Main screen, pressing the screen will lead back to the Main screen.		
Model info	The Model info screen shows the transducer type and model number and each screen has different extra information. Press the screen to toggle through the different info screens and eventually go back to Settings.		
	Model info (1/4)	Model info (2/4)	Model info (3/4)
	Transducer P/N	Gas type	Interface type
	Serial number	Transducer firmware version	Connector type
	User tag	Display firmware version	Number of available relays
	Communication address	RS485 testing	Setpoint delay 50ms ON/OFF
	Baud rate	Pressure unit	
		Transducer ON-time	
Unit	The Unit screen displays the current pressure unit and gives the possibility to change the pressure unit between Torr, Millibar or Pascal.		
Screen rotation	The Screen Rotation screen displays the current screen orientation and enables the operator to rotate the screen in four directions.		
Alarm	A visual alarm can be set at a certain pressure. Press the green or red button to enable or disable the alarm. Press Set to change the alarm pressure value and triggering direction.		
	Set Alarm (1/2)		
	Setting pressure threshold: The alarm value is set by selecting a digit (left and right arrow) and cycling through the numbers 0-9 and +/- (press up arrow or screen) To accept, press right arrow until a green checkmark appears. Press again to proceed. To cancel, press left arrow until a red arrow appears. Press again to proceed.		
	Set Alarm (2/2)		
	When the alarm is set, the operator selects whether the alarm triggers above or below the given value.		

## Cold Cathode Sensor Control

The cold cathode sensor must be turned on before the transducer can provide pressure measurement values. The 971B can be controlled via digital interface, external analog control or manually.



P/N: 971B-x1090-0001, will always enable the high voltage when power is turned on. Power supply must be external controlled by switching power (pin 4) on and off to avoid continuously operation at high pressure.

### Digital Control of Cold cathode

Turn on Cold Cathode high voltage:

Command:	@253FP!ON;FF
Command values:	ON, OFF, ALWAYSON
Command reply:	@253ACKON;FF
Query:	@253FP?;FF
Query reply:	@253ACKOFF;FF
Factory default:	OFF

If FP is set to "ALWAYSON" the Cold Cathode high voltage will be turned on immediately when the transducer is powered on. Use power supply to control the transducer and prevent operation at higher pressure.

### Analog Control of Cold cathode

The cold cathode can be controlled by external equipment by shorting pin 13 to power supply ground pin 4. The analog controller can either be momentarily pulse triggered or low level triggered.

#### Analog Level trig (factory default)

When enabling level trig the cold cathode sensor will be on when pin 13 is shorted to ground pin 4 and turned off when pin 13 is floating.

Enabling level trig:

Command:	@253SW!OFF;FF
Command reply:	@253ACKOFF;FF

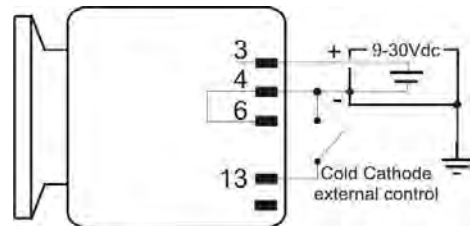

#### Analog Pulse trig

When enabling pulse trig the cold cathode sensor will be turn on when cold cathode enable (pin 13) is shorted momentarily to ground (pin 4) and turned off when cold cathode enable (pin 13) is shorted momentarily to ground (pin 4) again.

Enabling pulse trig:

Command:	@253SW!ON;FF
Command reply:	@253ACKON;FF
Query:	@253SW?;FF
Query reply:	@253ACKON;FF
Factory default:	OFF



**Cold cathode external control pin 13 must be floating or shorted to power supply ground pin 4. Do not connect to a voltage source. Connection to voltage source can cause permanent damage to the transducer.**

### Manual Control of Cold cathode

The cold cathode can also be controlled by pressing the user switch. The Cold Cathode can either be activated or deactivated by pressing the switch momentarily (SW!ON) or activated while pressing down the switch (SW!OFF). The 971B is per factory default delivered with SW turned off.



### Pressure output

The 971B transducer can provide pressure measurement output as an analog voltage or RS232/RS485 digital value. The digital value is 3 digits scientific notation for PR1, PR3, PR5 reading and 4 digits for PR4 reading.

---

Pressure request:

Query: @253PR1?;FF  
Query reply: @253ACK1.23E-4;FF

Pressure outputs:

PR1: Cold Cathode reading  
PR2: Cold Cathode reading  
PR3: Cold Cathode reading  
PR5: Cold Cathode reading

The default analog output is based on the combined PR1 reading and provides a 16 bit voltage output of 0.5 VDC/decade standard configuration. Refer to Analog output page 25 for details.



**If ionization does not ignite or if the cold cathode reading is lower than the cold cathode zero value, the digital and analog output provides: 1.00E-8 Torr**



When designing pressure data collecting software and controlling loop, make sure that the software does not interpret a communication error as a valid pressure value.

### Resolution

The digital pressure output can provide 3 digit or 4 digit values; however, the resolution is limited in certain parts of the measuring range.

1.00E-7 to 1.00E-8 Torr	2 digits resolution	1.50E-8
5.00E-3 to 1.00E-7 Torr	3 digits resolution	1.230E-4

### Measuring noise

External sources can interfere with the sensor signal and cause noise in the signal. The low measuring range is most sensitive to measuring noise due to low signal levels.

### Magnetic interference

External magnetic sources can interfere with the Cold Cathode sensor and cause measurement deviation from actual pressure. Avoid having magnetic material located close to the 971B Transducer.

### Cold Cathode ignition startup

When the Cold Cathode high voltage is enabled, an ignition delay may occur. The ignition waiting time is from less than a second at high pressures to minutes at low pressures. The ignition time is a function of gas density and cleanness of the gauge.

When the Cold Cathode is enabled, but ionization not ignited the LED will flash red. The LED will flash green when valid measurements are present.

Pressure	Typical ignition time
1.00E-8 Torr	≈12 Minutes
1.00E-6 Torr	≈10 Seconds
1.00E-4 Torr	≈1 Second

---

### Cold Cathode protect setpoint

The Cold Cathode protect setpoint automatically turns off the Cold Cathode high voltage if the cold cathode measurement exceeds 5.00E-3 Torr for 120 seconds. The protect setpoint can be turned off (disabled) or time set between 0 and 999 seconds.

Command: @253PRO!ON;FF  
Command values: ON (120), OFF, 0 to 999 seconds

Command reply: @253ACK120;FF  
Query: @253PRO?;FF  
Query reply: @253ACK120;FF  
Factory default: OFF



If FP is set to "ALWAYSON" the protect setpoint is automatically disabled. (See page 15)

### Cold cathode pressure dose

The Cold Cathode pressure dose continuously monitors the Cold Cathode time on as function of the pressure. If the cold cathode is on for 100 hours at 1E-4 Torr the pressure dose is  $100 \times 1E-4 = 1E-2$  Torr hours. The pressure dose readout can be used to determine the time interval between Cold Cathode maintenance and service.

Pressure dose request:

Query: @253TIM3?;FF  
Query reply: @253ACK1.23E-2;FF

Reset of pressure dose:

Command: @253TIM3!;FF  
Command values: -

The pressure dose reading can be user reset after the transducer has been cleaned or the anode assembly has been replaced.



The pressure dose reading is only a rough indication of the cold cathode status. When the cold cathode is contaminated the sensitivity of the gauge is decreased and it will provide a lower reading than actual pressure. Therefore the calculated pressure dose can be lower than the actual pressure dose.

### Cold Cathode pressure dose setpoint

The Cold Cathode protect setpoint can be used to determine when a defined pressure dose is exceeded. The transducer status readout (see page 21) is used to monitor pressure dose setpoint status.

Command: @253PD!1.00E-2;FF  
Command values: 1.00E-3 to 10 Torr

Command reply: @253ACK;FF  
Query: @253PD?;FF  
Query reply: @253ACK120;FF  
Factory default: 1.00E+00

---

## Calibration and Adjustment

The 971B is factory calibrated when delivered and in many applications further calibration is not required. If the sensor element has been contaminated or damaged by process gases, adjustment of zero and full scale can be executed to compensate for small measurement errors.

### Pressure unit setting

The transducer can provide digital and analog output in torr, mbar and Pascal pressure units. When changing pressure unit all parameters such as setpoint settings are automatically converted to the new unit, so it will represent the same pressure level. All pressure parameters such as setpoint settings and calibration values must be entered in the actual transducer unit setting.

Change of pressure unit calibration setup:

Command:	@253U!PASCAL;FF
Command values:	TORR, MBAR, PASCAL
Command reply:	@253ACKPASCAL;FF
Query:	@253U?;FF
Query reply:	@253ACKTORR;FF
Factory default:	TORR

The torr unit is most common in the US and mbar is most common in Europe. Pascal is the official pressure unit as specified by SI (from the French *Le Système International d'Unités*) and is widely used in Asia.

### Cold cathode zero adjustment

The Cold Cathode zero adjustment allows the user to adjust the cold cathode zero reading.

### Executing zero adjustment

To obtain measuring performance the transducer should be evacuated to pressure below  $5 \times 10^{-8}$  Torr.



If the Cold Cathode zero adjustment is executed at high pressure, the measurement below the zero value can become unreliable. Always zero at the system base pressure.

Command:	@253VAC3!2.00E-8;FF
Command values:	1.00E-6 to 1.00E-8 Torr
Command reply:	@253ACK;FF
Query:	@253VAC3?;FF
Query reply:	@253ACK0.00+00;FF
Reset to default:	@253FD!VAC3;FF
Factory default:	<i>Factory adjustment value</i>
Value out off range:	@253NAK172;FF

### Cold cathode full scale adjustment

The Cold Cathode full scale adjustment allows the user to adjust the cold cathode reading at high pressure.

Command:	@253CFS!4.00E-3;FF
Command values:	1.00E-4 to 5.00E-3 Torr
Command reply:	@253ACK;FF
Query:	@253CFS?;FF
Query reply:	@253ACK0.00E+0;FF
Reset to default:	@253FD!CFS;FF
Factory default:	<i>Factory adjustment value</i>
Value out off range:	@253NAK172;FF

## Factory Defaults

The transducer is per factory default delivered with parameters and setup as listed below. If the transducer is delivered with customer preconfigured parameters, the values are different than listed below and the parameters will be locked per default.

### Communication parameters:

Description	Command	Parameter	FD!	FD!ALL
Address:	AD!	253	-	x
Baud rate:	BR!	9600	-	x
Communication delay:	RSD!	ON	-	x

### Transducer parameters:

Description	Command	Parameter	FD!	FD!ALL
Test mode (LED flash):	TST!	OFF	x	x
User tag:	UT!	MKS	-	x
Set point 1 value:	SP1!	1.00E0	-	x
Set point 1 hysteresis value:	SH1!	1.10E0	-	x
Set point 1 direction:	SD1!	BELOW	-	x
Set point 1 enable:	EN1!	OFF	-	x
Set point 2 value:	SP1!	1.00E0	-	x
Set point 2 hysteresis value:	SH1!	1.10E0	-	x
Set point 2 direction:	SD1!	BELOW	-	x
Set point 2 enable:	EN1!	OFF	-	x
Set point 3 value:	SP1!	1.00E0	-	x
Set point 3 hysteresis value:	SH1!	1.10E0	-	x
Set point 3 direction:	SD1!	BELOW	-	x
Set point 3 enable:	EN1!	OFF	-	x
Setpoint safety delay:	SPD!	ON	-	x
Cold Cathode protect setpoint	PRO!	OFF	-	x
Switch enable:	SW!	OFF	-	x
Analog out 1:	AO1!	30 <sup>(1)</sup>	-	x

(1) If the transducer is delivered with other analog output than standard mks (part number specified), then the factory default value will be specified by the specials part number.

### Calibration setup:

Description	Command	Parameter	FD!	FD!ALL
Gas calibration:	GT!	NITROGEN	x	x
CC Vacuum adjustment:	VAC3!	<i>Factory adjustment value</i>	x	x
Pressure unit:	U!	TORR	-	x

## Resetting to factory default

The factory default command resets all or certain parameters of the 971B to factory default settings as listed above. If other digital communication setup than factory default values are used, then the communication will be lost after execution of factory default and the transceiver equipment should be set to transducer values.



**The factory default command resets parameters to default values and consequently user adjustments, setup and factory configured parameters are lost. Use with caution!**

Command: @253FD!ALL;FF  
 Command values: None, ALL, UNLOCK, LOCK, VAC3

Command reply: @253ACKFD;FF

---

## Transducer Lock Function

To ensure that no unauthorized personal are able to change transducer setup and parameters, the transducer lock function can prevent direct access to parameter changes. Transducers delivered with pre-configured custom specified parameters (special part number) are per default locked and will reply with "NAK180", if the user tries to change locked parameters. The unlock procedure must be executed to change these parameters.

### Disable lock function command:

Command: @253FD!UNLOCK;FF  
Command reply: @253ACKFD;FF

### Enable lock function command:

Command: @253FD!LOCK;FF  
Command reply: @253ACKFD;FF

Standard transducer (7 digits part number: 971B-xxxx)  
Factory default: *Transducer unlocked*

Special configuration transducer (11 digits part number: 971B-xxxx-xxxx)  
Factory default: *Transducer locked*



**If the transducer is delivered with special configuration, the lock function will only be temporarily disabled and will be enabled again after cycling power cycle or executing the enable lock command.**



**The 971B transducer can be delivered with factory locked tamperproof settings for safety interlock applications. This option is defined in the special settings. If delivered with factory lock the transducer settings can only be changed by return of gauge to MKS.**

## User Switch Command

The User Switch command defines if the Cold Cathode sensor voltage is turned on by level trig or pulse trig. For details see Cold Cathode sensor control.

Command: @253SW!OFF;FF  
Command values: ON,OFF

Command reply: @253ACKOFF;FF  
Query: @253SW?;FF  
Query reply: @253ACKON;FF  
Factory default: OFF

## Transducer Test

The transducer test command can be used to visually identify a transducer. If the test mode is enabled the LED will flash with a 1 sec. cycle.

Command: @253TST!ON;FF  
Command values: ON,OFF

Command reply: @253ACKON;FF  
Query: @253TST?;FF  
Query reply: @253ACKON;FF  
Factory default: OFF

---

## Status Query Commands

### Device Type - DT

Specifies transducer device type name:

Query: @253DT?;FF  
Query reply: @253ACKUNIMAG;FF

### Firmware Version - FV

Specifies transducer firmware version: Query:

@253FV?;FF  
Query reply: @253ACK1.12;FF

### Hardware Version - HV

Specifies transducer hardware version:

Query: @253HV?;FF  
Query reply: @253ACKA;FF

### Manufacturer - MF

Specifies transducer manufacturer:

Query: @253MF?;FF  
Query reply: @253ACKMKS;FF

### Model - MD

Specifies transducer model number:

Query: @253MD?;FF  
Query reply: @253ACK971B;FF

### Part Number - PN

Specifies transducer part number:

Query: @253PN?;FF  
Query reply: @253ACK971B-11030;FF

### Serial Number - SN

Specifies transducer serial number:

Query: @253SN?;FF  
Query reply: @253ACK0825123456;FF

### Time ON - TIM

The TIM command returns the number of hours the transducer has been on:

Query: @253TIM?;FF  
Query reply: @253ACK123;FF

### Cold Cathode Time ON – TIM2

The TIM2 command returns the number of hours the cold cathode high voltage has been on:

Query: @253TIM2?;FF  
Query reply: @253ACK123;FF

### Cold Cathode pressure dose – TIM3

The TIM3 command returns the cold cathode pressure dose. (Refer to page 17)

Query: @253TIM3?;FF  
Query reply: @253ACK1.23E-4;FF

### Transducer Status – T

The T command returns the Transducer sensor status as O for OK, C for Cold Cathode failure or G for Cold Cathode ON.

Query: @253T?;FF  
Query reply: @253ACKO;FF



## Analog Output

The 971B transducer provides a voltage output as function of pressure.  
The standard output is 0.5 VDC/decade but can also be configured to emulate other analog outputs.

### Analog output calibration = 0 (MKS standard 0.5 VDC/decade)

$$P_{\text{Torr}} = 10^{(2 \times V_{\text{out}} - 11)}$$

$$V_{\text{out}} = \frac{\text{Log}_{10}(P_{\text{Torr}}) + 11}{2}$$

$$P_{\text{mbar}} = 10^{(2 \times V_{\text{out}} - 11)}$$

$$V_{\text{out}} = \frac{\text{Log}_{10}(P_{\text{mbar}}) + 11}{2}$$

$$P_{\text{Pascal}} = 10^{(2 \times V_{\text{out}} - 9)}$$

$$V_{\text{out}} = \frac{\text{Log}_{10}(P_{\text{Pascal}}) + 9}{2}$$

The standard MKS analog output always provides 0.5 VDC/decade. If the transducer pressure unit is changed from Torr to Pascal or mbar the analog output scaling will change as well, so it represents 0.5 VDC/decade Torr or 0.5 VDC/decade mbar or Pascal.

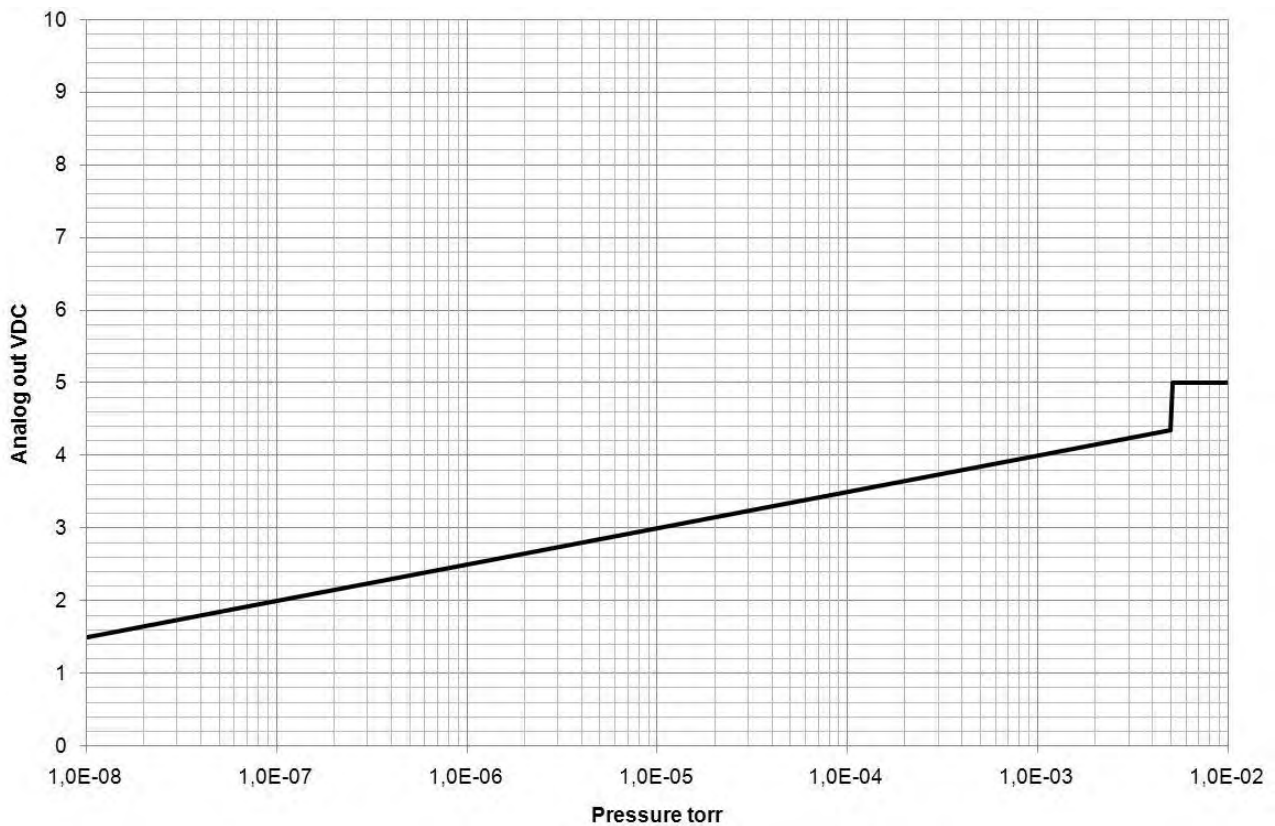

Torr/mbar	Vout	Torr/mbar	Vout
1.0E-8	1.5000	1.0E-5	3.0000
2.0E-8	1.6505	2.0E-5	3.1505
4.0E-8	1.8010	4.0E-5	3.3010
6.0E-8	1.8891	6.0E-5	3.3891
8.0E-8	1.9515	8.0E-5	3.4515
1.0E-7	2.0000	1.0E-4	3.5000
2.0E-7	2.1505	2.0E-4	3.6505
4.0E-7	2.3010	4.0E-4	3.8010
6.0E-7	2.3891	6.0E-4	3.8891
8.0E-7	2.4515	8.0E-4	3.9515
1.0E-6	2.5000	1.0E-3	4.0000
2.0E-6	2.6505	2.0E-3	4.1505
4.0E-6	2.8010	4.0E-3	4.3010
6.0E-6	2.8891	5.0E-3	4.3494
8.0E-6	2.9515	OFF	5.0000

---

## Analog output setup

The 971B can emulate analog voltage outputs from other vacuum transducers. The 971B analog output can only be assigned to the Cold Cathode sensor measurement (PR1 to 5). This is set by the first digit. The second and third digit represents the analog output calibration. The primary analog output provides 16 bit resolution.



**Due to curve form and limits, some of the alternative analog outputs will cause loss of measuring range and accuracy. For best performance use the standard MKS analog output. Change of analog output setup does not interfere on digital reading.**

Change of analog output setup:

Command:	@253AO1!15;FF
Command values:	10 to 319 (xy)
First digit (x)	1 = PR1 (Cold cathode pressure value assignment)
Second digit (y)	0 = MKS Standard (0.5 VDC/decade) 1 = Edwards APG-L (1.99 -10 VDC) 2 = Edwards APG100 3 = Edwards WRG 4 = Inficon PSG500 /Oerlikon/Leybold TTR91 5 = Inficon MPG400 / Pfeiffer PKR251 6 = Inficon BPG400 / MKS 999 Quattro 7 = MKS GP275 8 = MKS Moducell 325 9 = MKS Moducell 325 (x3) 10 = MKS Baratron 0.1 Torr (0-10 VDC) 11 = MKS Baratron 1 Torr (0-10 VDC) / Hasting 2002OBE, Channel 2 12 = MKS Baratron 10 Torr (0-10 VDC) 13 = MKS Baratron 100 Torr (0-10 VDC) 14 = MKS Baratron 1000 Torr (0-10 VDC) / Hasting 2002OBE, Channel 1 15 = Piezo differential output 16 = Edwards AIM-S /-SL 17 = Edwards AIM-X / XL 18 = Pfeiffer IKR251 19 = Pfeiffer TPR 265 20 = OBE Channel 2 21 = Edwards DV6M 22 = Edwards APG-M
Command reply:	@253ACK15;FF
Query:	@253AO1?;FF
Query reply:	@253ACK105;FF
Factory default:	30

### Analog output calibration = 3 (Edward WRG emulation)

The WRG emulation covers a wider measuring range than supported by the 971B range.

$$P_{Torr} = 10^{(1.5 \times V_{out} - 12.125)}$$

$$P_{mbar} = 10^{(1.5 \times V_{out} - 12)}$$

$$P_{Pascal} = 10^{(1.5 \times V_{out} - 10)}$$

$$V_{out} = (\log_{10}(P_{Torr}) + 12.125) / 1.5$$

$$V_{out} = (\log_{10}(P_{mbar}) + 12) / 1.5$$

$$V_{out} = (\log_{10}(P_{Pascal}) + 10) / 1.5$$

Torr	mbar	Pascal	Vout
1.00E-8	1.33E-8	1.33E-6	2.75
2.37E-8	3.16E-8	3.16E-6	3.00
7.50E-7	1.00E-6	1.00E-4	4.00
2.37E-5	3.16E-5	3.16E-2	5.00
7.50E-4	1.00E-3	1.00E-1	6.00
2.37E-2	3.16E-2	3.16	7.00
7.50E-1	1.00	100	8.00
2.37	31.6	3.160	9.00
750.0	1.000	100.000	10.00

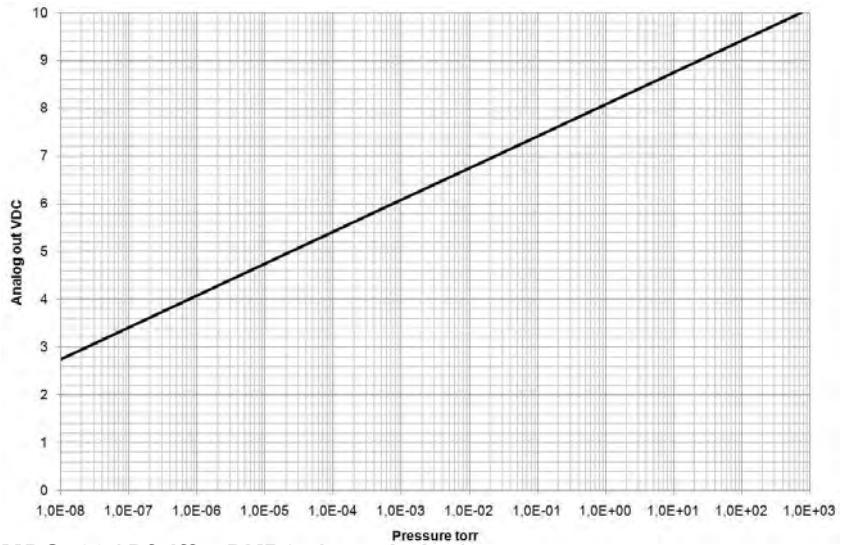

### Analog output calibration = 5 (Inficon MPG400 / Pfeiffer PKR251 emulation)

$$P_{Torr} = 10^{((V_{out} - 6.875)/0.6)}$$

$$P_{mbar} = 10^{((V_{out} - 6.8)/0.6)}$$

$$P_{Pascal} = 10^{((V_{out} - 5.6)/0.6)}$$

$$V_{out} = \log_{10}(P_{Torr}) \times 0.6 + 6.875$$

$$V_{out} = \log_{10}(P_{mbar}) \times 0.6 + 6.8$$

$$V_{out} = \log_{10}(P_{Pascal}) \times 0.6 + 5.6$$

Torr	mbar	Pascal	Vout
1.00E-8	1.33E-8	1.33E-6	2.075
1.00E-7	1.33E-7	1.33E-5	2.675
1.00E-6	1.33E-6	1.33E-4	3.275
1.00E-5	1.33E-5	1.33E-3	3.875
1.00E-4	1.33E-4	1.33E-2	4.475
1.00E-3	1.33E-3	1.33E-1	5.075
1.00E-2	1.33E-2	1.33E+0	5.675
1.00E-1	1.33E-1	1.33E+1	6.275
1.00E+0	1.33E+0	1.33E+2	6.875
1.00E+1	1.33E+1	1.33E+3	7.475
1.00E+2	1.33E+2	1.33E+4	8.075
7.60E+2	1.01E+3	1.01E+5	8.603

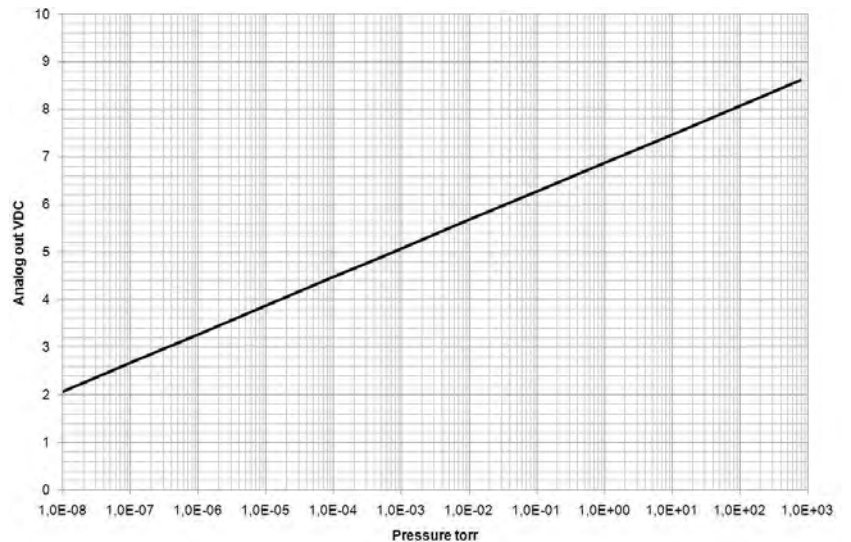

## Analog output calibration = 6 (Inficon BPG400 emulation)

$$P_{\text{Torr}} = 10^{((V_{\text{out}} - 7.75)/0.75)} - 0.125$$

$$P_{\text{mbar}} = 10^{(V_{\text{out}}/0.75)}$$

$$P_{\text{Pascal}} = 10^{(V_{\text{out}}/0.75)+2}$$

$$V_{\text{out}} = \log_{10}(P_{\text{Torr}} + 0.125) \times 0.75 + 7.75$$

$$V_{\text{out}} = \log_{10}(P_{\text{mbar}}) \times 0.75$$

$$V_{\text{out}} = \log_{10}(P_{\text{Pascal}} - 2) \times 0.75$$

Torr	mbar	Pascal	Vout
1.00E-8	1.33E-8	1.33E-6	1.843
1.00E-7	1.33E-7	1.33E-5	2.593
1.00E-6	1.33E-6	1.33E-4	3.343
1.00E-5	1.33E-5	1.33E-3	4.093
1.00E-4	1.33E-4	1.33E-2	4.843
5.00E-4	6.67E-4	6.67E-2	5.367
1.00E-3	1.33E-3	1.33E-1	5.593
1.00E-2	1.33E-2	1.33E+0	6.343
1.00E-1	1.33E-1	1.33E+1	7.093
1.00E+0	1.33E+0	1.33E+2	7.843
1.00E+1	1.33E+1	1.33E+3	8.593
1.00E+2	1.33E+2	1.33E+4	9.343
7.60E+2	1.01E+3	1.01E+5	10.004

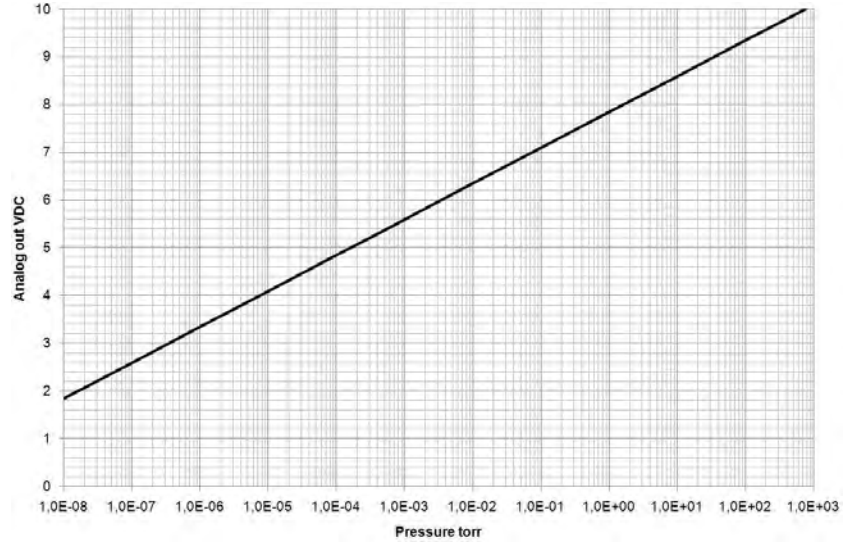

## Analog out calibration = 16 (Edwards AIM-S /-SL)

The Edwards AIM-S / SL emulation provides a strongly non linear output.

Torr	mbar	Pascal	Vout
1.00E-8	1.33E-8	1.33E-6	2.5
1.80E-8	2.40E-8	2.40E-6	2.5
4.40E-8	5.87E-8	5.87E-6	3
6.10E-8	8.13E-8	8.13E-6	3.2
8.30E-8	1.11E-7	1.11E-5	3.4
1.10E-7	1.47E-7	1.47E-5	3.6
2.20E-7	2.93E-7	2.93E-5	4
5.50E-7	7.33E-7	7.33E-5	4.6
7.40E-7	9.87E-7	9.87E-5	4.8
9.80E-7	1.31E-6	1.31E-4	5
1.30E-6	1.73E-6	1.73E-4	5.2
2.10E-6	2.80E-6	2.80E-4	5.6
3.40E-6	4.53E-6	4.53E-4	6
4.20E-6	5.60E-6	5.60E-4	6.2
5.20E-6	6.93E-6	6.93E-4	6.4
7.50E-6	1.00E-5	1.00E-3	6.8
9.00E-6	1.20E-5	1.20E-3	7
1.10E-5	1.47E-5	1.47E-3	7.2
2.20E-5	2.93E-5	2.93E-3	8
3.20E-5	4.27E-5	4.27E-3	8.4
4.30E-5	5.73E-5	5.73E-3	8.6
5.90E-5	7.87E-5	7.87E-3	8.8
9.00E-5	1.20E-4	1.20E-2	9
1.40E-4	1.87E-4	1.87E-2	9.2
2.5E-4	3.33E-4	3.33E-2	9.4
5.0E-4	6.67E-4	6.67E-2	9.6
1.3E-3	1.73E-3	1.73E-1	9.8
2.7E-3	3.60E-3	3.60E-1	9.9
7.5E-3	1.00E-2	1.00E0	10

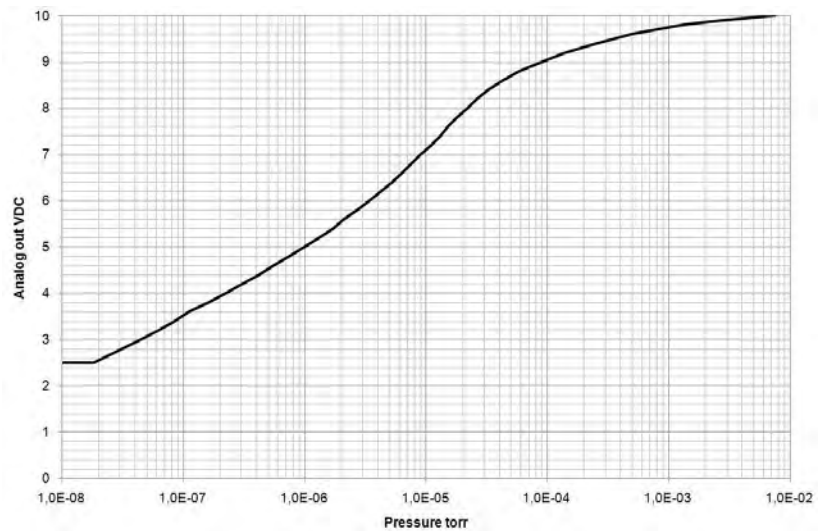

Cold cathode off,  $V_{\text{out}} = 1.5$  VDC

### Analog out calibration = 17 (Edwards AIM-X /-XL)

The Edwards AIM-X / XL emulation provides a log linear output.

Torr	mbar	Pascal	Vout
1.00E-8	1.33E-8	1.33E-6	3.286
5.00E-8	6.67E-8	6.67E-6	4.084
1.00E-7	1.33E-7	1.33E-5	4.428
5.00E-7	6.67E-7	6.67E-5	5.227
1.00E-6	1.33E-6	1.33E-4	5.571
5.00E-6	6.67E-6	6.67E-4	6.370
1.00E-5	1.33E-5	1.33E-3	6.714
5.00E-5	6.67E-5	6.67E-3	7.513
1.00E-4	1.33E-4	1.33E-2	7.857
5.00E-4	6.67E-4	6.67E-2	8.656
1.00E-3	1.33E-3	1.33E-1	9.000
5.00E-3	6.67E-3	6.67E-1	9.799

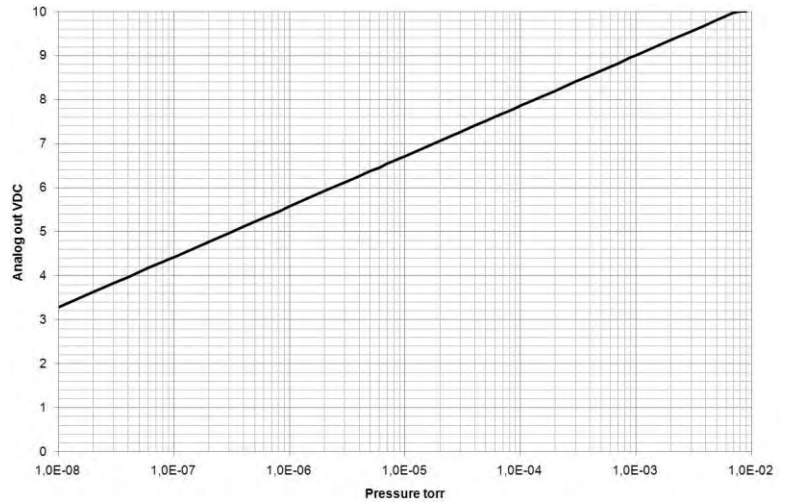

### Analog out calibration = 18 (Pfeiffer IKR251)

The Pfeiffer IKR251 emulation provides a log linear output.

Torr	mbar	Pascal	Vout
5.00E-9	6.67E-9	6.67E-7	2.3240
1.00E-8	1.33E-8	1.33E-6	2.6250
5.00E-8	6.67E-8	6.67E-6	3.3240
1.00E-7	1.33E-7	1.33E-5	3.6250
5.00E-7	6.67E-7	6.67E-5	4.3240
1.00E-6	1.33E-6	1.33E-4	4.6250
5.00E-6	6.67E-6	6.67E-4	5.3240
1.00E-5	1.33E-5	1.33E-3	5.6250
5.00E-5	6.67E-5	6.67E-3	6.3240
1.00E-4	1.33E-4	1.33E-2	6.6250
5.00E-4	6.67E-4	6.67E-2	7.3240
1.00E-3	1.33E-3	1.33E-1	7.6250
5.00E-3	6.67E-3	6.67E-1	8.3240
9.00E-3	1.20E-2	1.20E+0	8.5000

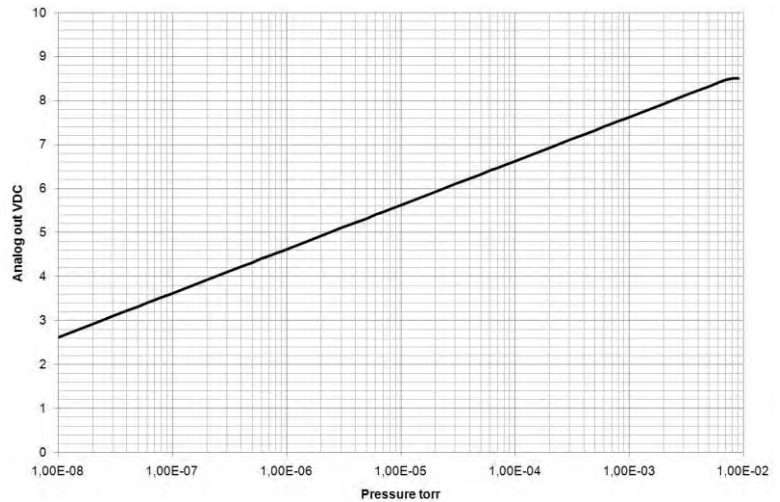

## Query Command List

### Communication information

Command	Response	Explanation
@xxxBR?;FF	@xxxACK9600;FF	Communication baud rate (4800, 9600, 19200, 38400, 57600, 115200,230400)
@xxxAD?;FF	@xxxACK253;FF	Transducer communication address (001 to 253)
@xxxRSD?;FF	@xxxACKON;FF	Communication delay between receive and transmit sequence.

### Pressure reading

Command	Response	Explanation
@xxxPR1?;FF	@xxxACK1.23E-5;FF	MicroPirani sensor pressure as 3 digit floating point value.
@xxxPR2?;FF	@xxxACK1.23E-5;FF	Cold Cathode sensor pressure as 3 digit floating point value.
@xxxPR3?;FF	@xxxACK1.23E-5;FF	Combined Cold Cathode and MicroPirani pressure (3 digits).
@xxxPR4?;FF	@xxxACK1.234E-5;FF	Combined Cold Cathode and MicroPirani pressure (4 digits).
@xxxPR5?;FF	@xxxACK1.234E-5;FF	Cold Cathode sensor pressure as 3 digit floating point value.

### Setpoint information

Command	Response	Explanation
@xxxSS1?;FF @xxxSS2?;FF @xxxSS3?;FF	@xxxACKSET;FF	Set point relay 1-3 status (SET=Relay energized / CLEAR=Relay deenergized)
@xxxSP1?;FF @xxxSP2?;FF @xxxSP3?;FF	@xxxACK1.00E-2;FF	Set point 1-3 switch value.
@xxxSH1?;FF @xxxSH2?;FF @xxxSH3?;FF	@xxxACK1.10E-2;FF	Set point 1-3 hystereses switch value.
@xxxEN1?;FF @xxxEN2?;FF @xxxEN3?;FF	@xxxACKOFF;FF	Set point 1-3 enable status ( OFF, CC=Cold Cathode)
@xxxSD1?;FF @xxxSD2?;FF @xxxSD3?;FF	@xxxACKBELOW;FF	Set point relay direction (ABOVE or BELOW) If set to above relay will be energized above setpoint value. If set to below relay will be energized below setpoint value.

### Transducer information

Command	Response	Explanation
@xxxMD?;FF	@xxxACK971B;FF	Model number (971B)
@xxxDT?;FF	@xxxACKUniMag;FF	Device type name (UniMag)
@xxxMF?;FF	@xxxACKMKS;FF	Manufacturer name (MKS)
@xxxHV?;FF	@xxxACKA;FF	Hardware version
@xxxFV?;FF	@xxxACK1.12;FF	Firmware version
@xxxSN?;FF	@xxxACK10350123456;FF	Serial number
@xxxSW?;FF	@xxxACKON;FF	Switch enable
@xxxTIM?;FF	@xxxACK123;FF	Time on (hours of operation)
@xxxTIM2?;FF	@xxxACK24;FF	High voltage time on (hours of operation with HV enabled)
@xxxTIM3?;FF	@xxxAC1.23E-3;FF	Cold cathode pressure dose
@xxxUT?;FF	@xxxACKVACUUM1;FF	User programmed text string (user tag)
@xxxT?;FF	@xxxACKO;FF	Transducer status check

### Calibration and adjustment information

Command	Response	Explanation
@xxxU?;FF	@xxxACKTORR;FF	Pressure unit setup (Torr, mbar or Pascal)
@xxxAO1?;FF	@xxxACK10;FF	Analog voltage output 1: Pressure assignment and calibration. (first digit is pressure assignment, second and third digit is calibration)

xxx = Transducer communication address (001 to 253. Broadcast addresses: 254, 255)

## Setup and configuration command list

### Setpoint setup and configuration

Command	Response	Explanation
@xxxSP1!2.00E+1;FF @xxxSP2!2.00E+1;FF @xxxSP3!2.00E+1;FF	@xxxACK2.00E+1;FF	Set point 1-3 switch value.
@xxxSH1!5.00E+1;FF @xxxSH2!5.00E+1;FF @xxxSH3!5.00E+1;FF	@xxxACK5.00E+1;FF	Set point 1-3 hysteresis switch value.
@xxxEN1!ON;FF @xxxEN2!ON;FF @xxxEN3!ON;FF	@xxxACKON;FF	Set point 1-3 enable status (ON or OFF)
@xxxSD1!BELOW;FF @xxxSD2!BELOW;FF @xxxSD3!BELOW;FF	@xxxACKBELOW;FF	Set point relay direction (ABOVE or BELOW) If set to above relay will be energized above setpoint value. If set to below relay will be energized below setpoint value.
@xxxSPD!ON;FF	@xxxACKON;FF	Setpoint safety delay (prevent pulse trig of setpoint)

### Communication setup

Command	Response	Explanation
@xxxBR!19200;FF	@xxxACK19200;FF	Set communication Baud rate (4800, 9600, 19200, 38400, 57600, 115200, 230400)
@xxxAD!123;FF	@xxxACK123;FF	Set transducer communication address (001 to 253)
@xxxRSD!OFF;FF	@xxxACKOFF;FF	Turn on or off communication delay between receive and transmit sequence.

### Calibration and adjustment

Command	Response	Explanation
@xxxU!MBar;FF	@xxxACKMBar;FF	Set pressure unit setup (Torr, mbar, Pascal)
@xxxVAC!;FF	@xxxACK;FF	Executes MicroPirani zero adjustment
@xxxATM!7.60E+2;FF	@xxxACK;FF	Executes MicroPirani full scale atmospheric adjustment.
@xxxVAC3!;FF	@xxxACK;FF	Executes Cold Cathode zero adjustment
@xxxAO1!10;FF	@xxxACK10;FF	Set analog voltage output 1 calibration
@xxxTIM3!;FF	@xxxACK;FF	Reset cold cathode pressure dose

### Information setup

Command	Response	Explanation
@xxxUT!UNIMAG;FF	@xxxACKUNIMAG;FF	Set transducer user tag

### User Switch

Command	Response	Explanation
@xxxSW!ON;FF	@xxxACKON;FF	Enable / disable user switch

xxx = Transducer communication address (001 to 253. Broadcast addresses: 254, 255)

---

## FAQ (Frequently Asked Questions)

### Applications

**Q:** *Can the transducer and sensor element continuously withstand vibrations from a mechanical fore-pump.*

**A:** Yes – the cold cathode sensor can withstand continuous vibrations.

**Q:** *When the transducer is pumped down and isolated by closing a valve the pressure is raising. Is the transducer leaking?*

**A:** Not likely - when a confined space is evacuated and the pumping is stopped, the pressure will rise because of out-gassing, mainly by water vapor. The pressure can easily rise to a few Torr over time.

**Q:** *When the transducer is leak checked on a helium leak detector, leak reading is building up slowly after approximately 30 seconds. Is the transducer leaking?*

**A:** No - the internal sealing of the 971B transducer uses elastomer viton sealing and consequently helium molecules can penetrate through the viton material and cause slow increase of helium leak readout. If a leaking transducer is tested directly on a helium leak detector the leak is almost instant displayed.

**Q:** *Can the transducer be mounted in any orientation?*

**A:** Yes - the transducer can be mounted in any orientation without compromise of performance or calibration. However, it is recommended not to mount the transducer with the flange port facing upwards to avoid contamination like particulates or liquids from entering the device.

**Q:** *Can the transducer withstand instant ventilation?*

**A:** Yes – However, it's not recommended to perform instant ventilation when the Cold Cathode is turn on.

**Q:** *Can I connect a valve to be controlled by the transducer relay contact?*

**A:** Driving inductive loads such as valves requires special precautions. Refer to detailed description page 12.

**Q:** *How many pressure cycles can the transducer withstand?*

**A:** Cold Cathode sensor element is very mechanical robust to pressure changes and there are no limits on the number of pressure cycles. In applications where fast pressure cycles occur, the Cold Cathode sensor can be sputtered and this can lead to change of accuracy.

**Q:** *The Cold Cathode sensor chamber has changed color, Why?*

**A:** If the Cold Cathode is operated at high pressure ( $>1.00E-4$  Torr) the cold cathode sensor module can be sputtered. This will change the color of the internal measuring chamber and can also result in change of measuring accuracy.

### Analog output

**Q:** *What is the update rate of the analog output?*

**A:** 16 times per second.

**Q:** *What is the maximum length of analog output cable?*

**A:** The length of analog cable depends on cable quality and electrical noise environment, but cable length up to 100 m do not normally require any special precautions other than the cable must be screened.

**Q:** *The digital reading is correct, but the analog output reading has some deviation from actual pressure?*

**A:** Check that the analog out is connected to a floating input and not an input that is connected to ground. If connected analog out return is connected to ground, the supply current will flow in the signal line and cause voltage drop and ground looping.

### Digital output

**Q:** *How fast can I request pressure measurements via the digital interface?*

**A:** 10 times per second is the fastest recommended pressure request frequency.

**Q:** *How long is the waiting time from turning power on to valid measuring values?*

**A:** The power on sequence is approximately 2 seconds. The LED is illuminating red during power up sequence and the digital interface will not reply to commands. The ionization can take a few minutes to stabilize. If the cold cathode is turned on at low pressure  $<1.00E-7$  Torr it can take several minutes before the ionization starts.

**Q:** *The first character is sometimes lost in the transducer digital communication reply?*



---

**A:** This can be caused by too fast transducer communication reply. See RS delay command description page 13.

**Q:** *Is it necessary to use the ground wire between RS485 communication equipment and transducer?*

**A:** Yes - both RS232 and RS485 communication requires a 3-wire connection between transducer and communication equipment.

### **Calibration and adjustment**

**Q:** *How often does the transducer require calibration or Zero adjustment?*

**A:** Calibration of cold cathode sensor is normally not required. The reading in the low range can be user calibrated by use of the VAC3 command.

**Q:** *How long is the warm up time before obtaining reliable measurements from the transducer?*

**A:** Reliable measurements are typically available within 5 minutes.

**Q:** *Will the transducer retain user calibration after power is shut off?*

**A:** Yes - all transducer parameters including calibration data are stored internally in the transducer non-volatile memory.

### **Service and repair**

**Q:** *Can the sensor element be cleaned if contaminated?*

**A:** Yes – The cold cathode internal sensor chamber can be cleaned using solvents compatible with 304 stainless steel 403 stainless steel, titanium, Ceramic (Al<sub>2</sub>O<sub>3</sub>), Viton® and epoxy resin.

**Q:** *Can the sensor element be changed if contaminated?*

**A:** Yes - the cold cathode anode module can be changed or cleaned. Refer to Service and Repair page 31.

**Q:** *How often does the Cold Cathode sensor require cleaning?*

**A:** Contaminants such as oil vapors from oil lubricated for pump will cause carbonaceous deposits which will affect sensitivity of the gauge. The cleaning interval depends on contamination type and pressure range, but can be down to a few hundred hours of Cold Cathode operation time. Cold Cathode time on can be read by using the command: @254TIM2?;FF

The anode module can be removed and mechanical polished or replaced.

**Q:** *+24 VDC supply voltage has been connected to analog output+. Is the transducer damaged?*

**A:** Likely - the analog output is not protected against applying power to the output pin.

**Q:** *Reverse voltage has been connected to power supply input. Is the transducer damaged?*

**A:** Not likely – the transducer power supply circuit has reverse voltage and over voltage protection however. MKS cannot guarantee that the transducer will not be damaged.

**Q:** *The status LED is constantly illuminating red?*

**A:** The red status indicates a defect sensor element. Refer to Service and Repair page 35.

## Troubleshooting

Symptom	Possible Cause/Remedy
<b>No digital communication</b>	<ul style="list-style-type: none"> <li>- Check electrical connections (3 wires from transducer to communication equipment)</li> <li>- Transducer and communication equipment baud rate matches</li> <li>- Use of incorrect transducer address. Try address 254</li> <li>- Attention characters missing (@)</li> <li>- Termination characters missing (;FF)</li> </ul>
<b>NAK180 is received when transmitting setpoint commands</b>	<ul style="list-style-type: none"> <li>- The transducer setup is locked. Refer to disable lock procedure page 19</li> </ul>
<b>Incorrect pressure value</b>	<ul style="list-style-type: none"> <li>- Other gas present than transducer gas setting or trace of gas.</li> <li>- Contaminated sensor. Transducer repair required.</li> <li>- Corroded sensor. Transducer repair required.</li> </ul>
<b>Incorrect pressure value at low pressure.</b>	<ul style="list-style-type: none"> <li>- Contaminated sensor. Transducer repair required.</li> <li>- Corroded sensor. Transducer repair required.</li> <li>- Incorrect Vac adjustment has been executed.</li> </ul>
<b>Incorrect pressure value at high pressure.</b>	<ul style="list-style-type: none"> <li>- Contaminated sensor. Transducer repair required.</li> <li>- Other gas or gas trace present than transducer gas setting.</li> </ul>
<b>Cold Cathode does not provide measurements.</b>	<ul style="list-style-type: none"> <li>- If the Cold cathode is turned on a low pressure <math>&lt;1.00E-7</math> Torr or is contaminated a delay can occur from turning on high voltage to the ionization begins.</li> </ul>
<b>Cold Cathode value is lower than actual pressure.</b>	<ul style="list-style-type: none"> <li>- If the Cold Cathode sensor has been operated a too high pressure or exposed to fast pressure cycles the sensor can be sputtered. Sputtering of sensor will normally provide lower reading than actual pressure.</li> </ul>
<b>Set point relay does not trip.</b>	<ul style="list-style-type: none"> <li>- Setpoint not enabled.</li> <li>- Setpoint value not set to proper value.</li> <li>- Setpoint direction is different than the user expects.</li> <li>- Check electrical connection.</li> <li>- Check part number to see if transducer has setpoint relays.</li> </ul>
<b>No analog output</b>	<ul style="list-style-type: none"> <li>- Power supply turned off.</li> <li>- Check electrical connections.</li> </ul>
<b>Status LED illuminating red</b>	<ul style="list-style-type: none"> <li>- Sensor element defect. Refer to Service and Repair page 35.</li> </ul>

## Service and Repair

When a Cold Cathode sensor is turned on and operated at pressures higher than  $1.0E-3$  Torr, the inside wall of the ionization chamber can be sputtered by ions formed by the high energetic plasma. Inert gases like argon are easier to ionize and consequently the sputter effect is more significant in such environment. If the transducer is contaminated, the pressure measurement will typically be lower than actual pressure. Sputtering can also be visually detected since the inside wall of the transducer changes color. When operated in oil lubricated pumping systems, hydrocarbons can cause contamination of cold cathode measuring cell. The cold cathode hour counter and pressure dose can be used to determine if service is required. (See page 20.)

If sputtering or contamination occurs, the ionization cell kit or anode module can be changed from the flanges side without disassembling the transducer electronics. The anode module (p/n: 970B-ANODE-FE<sup>(1)</sup>) and cell kit (p/n: 970B-CELLKIT) is available as spare parts. The basic accuracy of the cold cathode sensor can change after replacement of anode. The cell kit and anode module can also be cleaned by mechanical polishing.



P/N: 970B-ANODE-FE<sup>(1)</sup>



P/N: 970B-CELLKIT



Do not touch cell kit, anode module, screen, screws or clip ring by hand. If items are accidentally touched by hand, use alcohol to clean items.



### Changing the Cell kit

1. Turn power off and remove cable.
2. Dismount the transducer from the vacuum system.
3. Remove the clip ring (1) using a clip ring remove/insert tool (p/n: 100017193).
4. Remove the screen (2).
5. Unscrew the Torx (T6) screws (3) at the rear screen (4).
6. Remove the rear screen (4).
7. Insert the new screen (Do not touch by hand).
8. Insert the Torx (T6) screw (3) and tighten.
9. Insert the front screen (2) and clip ring (1).

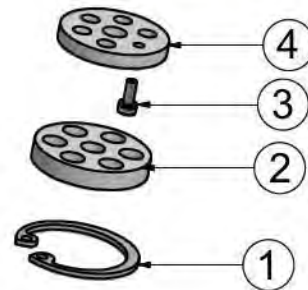

### Changing the Anode

1. Remove cell kit point 1-6
2. Unscrew the 3 screws at the anode module.
3. Remove the anode module and clean module or insert new.
4. Insert the anode module screw and DO NOT tighten. After all screws are inserted carefully tighten the screw a little and move on to the next one. Continue to tighten the screws one by one until all tight.
5. Perform leak testing of the transducer.
6. Insert cell kit point 7-9.

### Cleaning anode module and screens

Contaminated parts can be cleaned by mechanical polishing or ultrasonically cleaned followed by alcohol degreasing. Make sure that all parts are clean and remove any discoloring of the stainless steel and titanium parts. Alternatively, the anode module or screens can be replaced with new parts.

<sup>(1)</sup> For units with S/N: 1202347357 and lower use P/N: 970B-ANODE

## Specifications

Measuring range (N <sub>2</sub> and Air):		1×10 <sup>-8</sup> to 5×10 <sup>-3</sup> Torr
<b>Cold cathode</b>		
Accuracy Cathode <sup>(1)</sup>	1×10 <sup>-8</sup> to 1×10 <sup>-3</sup> Torr:	±30% of reading
Supply Voltage:		9 – 30 VDC
Power consumption:		< 2 Watt
Fuse (thermal recoverable):		200 mA
Analog output (MKS standard):		1-9 VDC
Analog output 1 resolution:		16 bit
Analog output 2 resolution:		12 bit
Analog output impedance:		100 Ω
Analog output update rate:		16 Hz
Setpoint relay range:		1×10 <sup>-8</sup> to 5×10 <sup>-3</sup> Torr
Setpoint relay contact rating:		1A / 30 VDC/AC (resistive load)
Setpoint relay contact resistance:		100 mΩ (max)
Setpoint relay contact endurance (30VDC/1A load):		100.000 (min)
Setpoint relay contact endurance (30VDC/0.2A load):		2.000.000 (min)
Setpoint relay response time:		<100 ms
Materials exposed to vacuum:		304 and 403 stainless steel, Viton®, Cu-Ni and Ag-Cu alloy, ceramic, titanium
Internal volume:	KF25 flange CF2.75" flange KF40 flange	3.6 cm <sup>3</sup> 1.9 cm <sup>3</sup> 3.1 cm <sup>3</sup>
Housing material:		Stainless steel 304
Flange material:		Stainless steel 304
Weight:	KF25 flange CF2.75" flange KF40 flange	360 g 570 g 390 g
Operating temperature:		0 to 40 °C (32 to 104 °F)
Bake out temperature (Power off):		85 °C (185 °F)
Humidity:		0 – 95% Non-condensing
Ingress Protection Rating:		IP40 / IP54 <sup>(2)</sup>

(1) Accuracy and repeatability are typical values measured in Nitrogen atmosphere when the transducer is new. (2) Special 925 version available with IP 54 rating.

**Dimensions KF25 flange (P/N: 971B-2xxx)**  
mm. [Inch.]

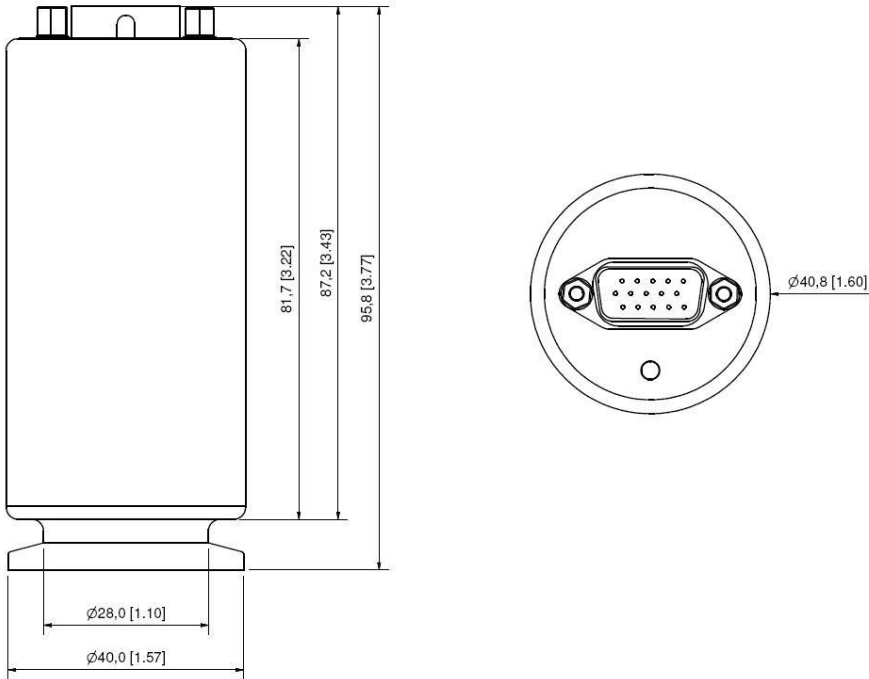

**Dimensions CF2.75" flange (P/N: 971B-7xxx)**  
mm. [Inch.]

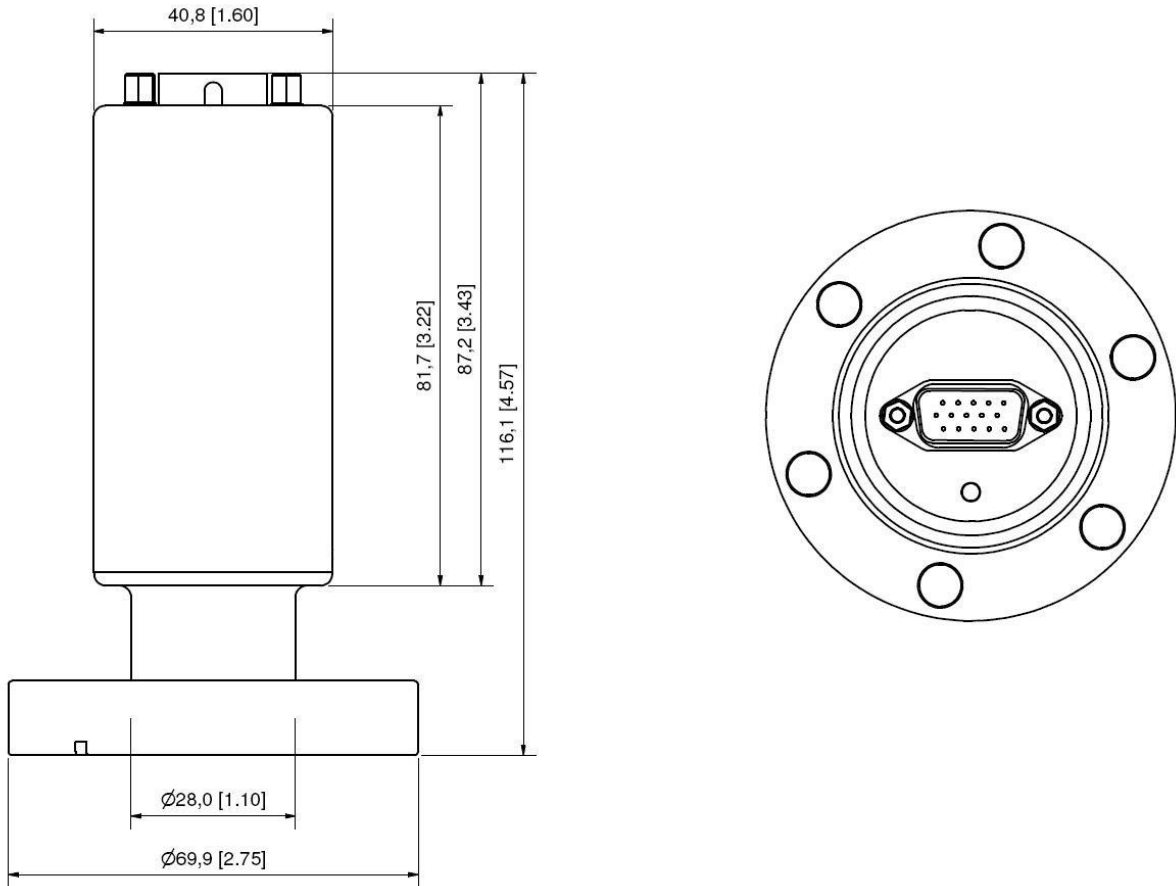

**Dimensions KF40 flange (P/N: 971B-9xxx)**  
mm. [Inch.]

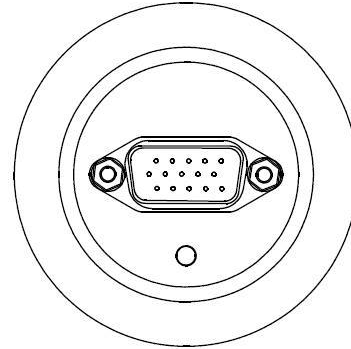
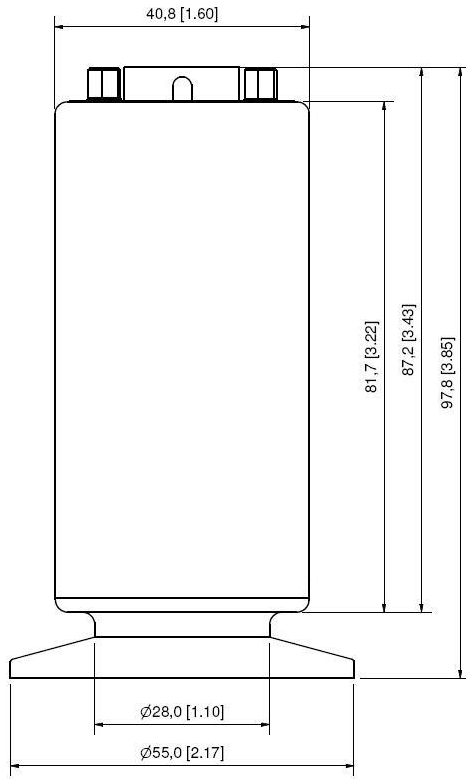

## Accessories and Replacement Parts

### PDR900 controller

Part number	Description	Interface
PDR900-12-EU	PDR900 Controller	EU Schuko power cable
PDR900-12-US	PDR900 Controller	US power cable
PDR900-12-UK	PDR900 Controller	UK power cable
PDR900-12-JP	PDR900 Controller	JP power cable. mbar / Pascal unit
PDR900-12-DK	PDR900 Controller	Danish power cable

### PDR900 Transducer Cables for 971B (15 pin HD DSUB)

For transducer part number: 971B-x12x, 971B-x13x, 971B-x15x

Part number	Description	Interface
100013620	3 m (10ft.)	RS232
100013621	5 m (16ft.)	RS232
100013622	7.6m (25ft.)	RS232
100013623	10 m (33ft.)	RS232

For transducer part number: 971B-x22x, 971B-x23x, 971B-x25x

Part number	Description	Interface
100013671	3 m (10ft.)	RS485
100013672	5 m (16ft.)	RS485
100013673	7.6m (25ft.)	RS485
100013674	10 m (33ft.)	RS485

### PDR900 Connectors & cables

Part number	Description
100010757	Setpoint Relay 3 pin connector
100013638	Analog output 8 pin connector
100013686	Analog output cable 3 meter (10ft.)
100013693	RS232/RS485 user communication cable 3 meter (10ft.)

### 971B Transducer calibration certificate

Part number	Description
100013147	DKD Calibration certificate Europe
100013200	Internal Calibration certificate Europe

### 971B Transducer repair kit

Part number	Description
971B-2REP	971B Sensor repair kit. KF25 flange
971B-7REP	971B Sensor repair kit CF2.75" flange
971B-9REP	971B Sensor repair kit. KF40 flange
970B-ANODEKIT-FE	Anode kit for 970 Series cold cathode Transducers
970B-CELLKIT	Ionization cell screen kit
100017192	Torx Driver, for Anode change
100017193	Circlip ring plier

## PDR 900 Display and Power Supply

- Plug and play readout for 900 Series transducers
- The easy way for setup and configuration
- Data logger tool for data analysing



## 900 Series VacuumLog software

- Data logger software
- Pressure curve plotting
- Rate of raise diagnostic tool
- Pump down monitoring
- Export of data to Excel spread sheet
- Windows 7 compatible

Free version available on:

<http://www.mksinst.com/vtsw/>

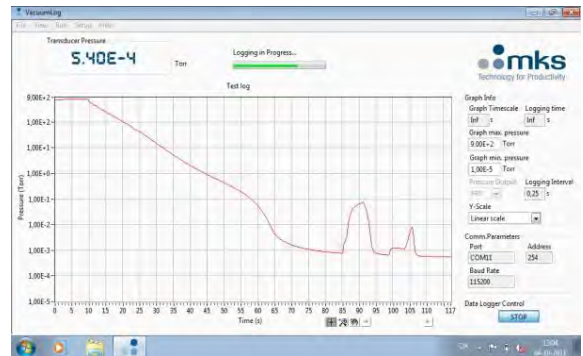



# Index

Accessories and replacement part numbers .....	36	Model .....	21
Accuracy .....	33	NAK Code .....	10
Addressing .....	11	NAK180 .....	13;20;31
Analog output .....	22;29	Operating temperature .....	33
Applications .....	4;29	Part number .....	3
Atmospheric adjustment .....	18	Part Number .....	21
Bake out .....	6	PDR900 .....	36
Bake out temperature .....	33	PDR900 controller relays .....	12
Baud rate .....	11	Pressure output .....	15;16
Calibration and adjustment .....	18	Process compatibility .....	6
Calibration certificate .....	36	Query Command list .....	27
CE Declaration of Conformity .....	37	RS232 user interface .....	9
CE marking .....	2	RS485 user interface .....	9
Communication delay .....	11	Safety information .....	2
Communication Protocol .....	10	Sensor Check .....	21
Communication software .....	10	Sensor technology .....	4
Contamination .....	6	Serial Number .....	21
Device Type .....	21	Serial user interface .....	9
Dimensions .....	34	Service and Repair .....	32
Display .....	14	Setpoint functionality .....	12
Disposal .....	4	Setpoint relay .....	12
Explosive Environments .....	2;6	Setup and configuration command list .....	28
Factory default .....	19	Specifications .....	33
Firmware Version .....	21	Supply Voltage .....	33
Frequently Asked Questions .....	29	Temperature .....	6
Fuse .....	2;33	Termination resistor .....	9
Grounding .....	2	Time ON .....	21
Hardware Version .....	21	Transducer installation (electrical) .....	7
Inductive relay load .....	12	Transducer installation (mechanical) .....	6
Input/Output Wiring .....	8	Trouble shooting .....	31
Internal volume .....	33	Unpacking .....	3
LED Status Indicator .....	5	User Switch .....	5;20
Lock function .....	20	Vacuum connections .....	6
Magnetic interference .....	2	Warranty .....	2
Manufacturer .....	21		



**971B UniMag™  
Vacuum Pressure Transducer  
RS232 / RS485 / Display**

**Operation and Installation Manual**

**P/N: 100017129  
971B UniMag™ Transducer  
Operation and Installation Manual  
Revision: J, February 2020**