

PDPCA

P-Series Dual-Zone DeviceNet™ Pressure Controller



The P-Series Dual-Zone Pressure Controller (PDPCA) is a highly integrated closed-loop pressure control subsystem. It consists of an inlet pneumatic shut-off valve, two independent channels of pressure control with mass flow metering, and a vacuum outlet. The pressure control channels consist of two P-Series pressure controllers (PPCMA). Each PPCMA provides both pressure control and flow metering.

The PDPCA has been designed to reduce the overall cost of ownership of pressure control subsystems for backside wafer cooling, specifically for the latest two-zone electrostatic chucks (Figure 1).

As shown in Figure 2, the PDPCA consists of four sections – an inlet subassembly, two PPCMA pressure control

channels and an outlet subassembly. Pressurized gas (typically helium) is provided in the inlet subassembly. A pneumatic valve is then opened and the gas flow is split to two pressure control channels.

In the pressure control section, the PPCMA utilize MKS Baratron® capacitance manometers to measure pressure for each of the two zones. These pressures are compared to the pressure set points and an appropriate signal adjusts the position of the solenoid control valve to bring actual pressures into agreement with the set points. At the same time, mass flow is monitored on each channel by MKS mass flow meters calibrated for helium, which is the typical gas used for backside wafer cooling.

Product Features

- Complete backside wafer cooling subsystem in a compact package
- Two independent channels of pressure control, each with mass flow metering
- With single package integration, size and complexity are reduced greatly
- Can be used in any application requiring independent pressure control and mass flow metering to two distinct volumes
- Tunable response for fast time to set point without pressure overshoot
- Control stability of $\pm 0.1\%$ of set point



Key Benefits

- Available with DeviceNet™ communications
- Less plumbing and cabling required
- Pressure measurement accuracy of $\pm 0.5\%$ of set point

Description

Downstream of the pressure control section, the outlet subassembly directs flow to the electrostatic chuck and provides a controlled "bleed" to vacuum through fixed orifices.

The purpose of the bleed is to insure that the pressure control system is not "dead-ended". Since leak past the wafer is typically very low, the controlled bleed provides additional pressure relief for faster response to set point.

The controlled bleed is done using a fixed orifice based on device outlet pressure of <math><1\text{ Torr}</math>. There is a choice of two orifice sizes for the controlled bleed. One is for a nominal flow of 13.5 sccm helium at a 14 Torr set point while the other is a nominal flow of 3.5 sccm of helium at a 9 Torr set point.

Communication and Control

The digital PDPCA features digital control electronics that are DeviceNet compliant communications.

To optimize pressure control performance, users may adjust gain, integral and differential (P, I, D) constants for each channel using the DeviceNet communications protocol. Control parameter adjustment may be required depending on system volume and pressure set points.

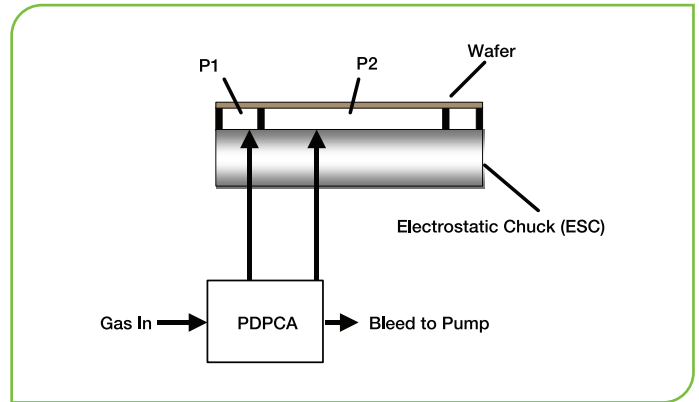

Figure 1 – Two Zone Backside Wafer Cooling

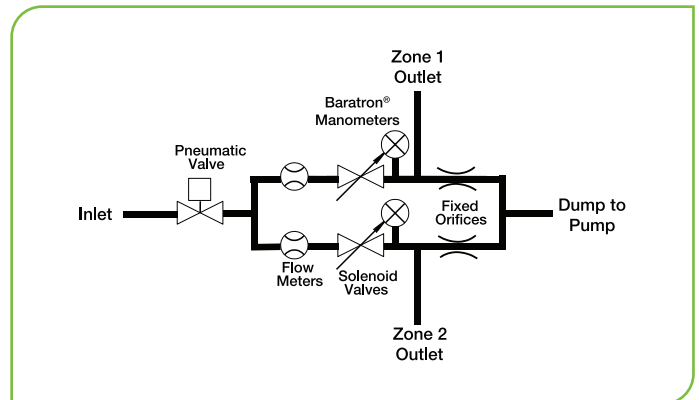

Figure 2 – PDPCA Functional Schematic

Specifications

Performance								
Accuracy	Pressure Control Accuracy Pressure Transducer Mass Flow Meter	<ul style="list-style-type: none"> • ±1.0% set point¹ • ±0.5% Reading • ±1.0% Full Scale² 						
Leak Integrity	Internal to External Through Closed Control Valve	<ul style="list-style-type: none"> • <10⁻⁹ scc/sec He • <1% Full Scale 						
Pressure Control	Range Stability at Set Point Control Time to Set Point ³	<ul style="list-style-type: none"> • 10-100% Full Scale • <0.1% set point • <2.0 seconds, typical - dependent on system configuration and control settings 						
Temperature Coefficient	Zero Span	<table border="0"> <tr> <td>Pressure</td> <td>Flow</td> </tr> <tr> <td>• <0.02% Full Scale/°C</td> <td>• <0.05% Full Scale/°C</td> </tr> <tr> <td>• <0.04% Reading/°C</td> <td>• <0.08% Reading/°C</td> </tr> </table>	Pressure	Flow	• <0.02% Full Scale/°C	• <0.05% Full Scale/°C	• <0.04% Reading/°C	• <0.08% Reading/°C
Pressure	Flow							
• <0.02% Full Scale/°C	• <0.05% Full Scale/°C							
• <0.04% Reading/°C	• <0.08% Reading/°C							
Warm Up Time		1 hour						
Mechanical								
Maximum Inlet Pressure		45 psia ⁴						
Dimensions (L x W x H)		<ul style="list-style-type: none"> • 10.46 in (incl. fittings) x 3.36 in x 5.35 in • 26.56 cm (incl. fittings) x 8.53 cm x 13.59 cm 						
Fittings		Swagelok® 4 VCR® male compatible						
Overpressure Limit		45 psia or 200% Full Scale, whichever is greater						
Full Scale Range	Pressure Flow	<ul style="list-style-type: none"> • 20, 50, or 100 Torr • 20, 50 or 100 sccm 						
Pressure Transducer		Absolute pressure capacitance manometer						
Surface Finish		Ra <10 μinches, electropolished						
Weight		10.5 lbs. (4.8 Kg)						
Wetted Materials		316L Stainless Steel, Inconel®, Nickel, Elgiloy®, Viton®						
Electrical		DeviceNet™						
Input Power Required		+11 to 25 VDC (<4 watts), each channel						
Connector		M8, 5 pin micro connector (Power and Communications), each channel						
Data Rate Switch/Selection		4 positions: 125, 250, 500K (Default), Programmable over network.						
Comm. Rate(s)		125 Kbps, 250 Kbps and 500 Kbps						
Mac ID Switches/Addresses		2 switches, 10 positions: 0,0 to 6,3. 1 to 254						
Network Size		Up to 64 nodes						
Visual Indicators		<ul style="list-style-type: none"> • LED Network (green/red) • LED Module (green/red) 						
Compliance		CE						
Environmental								
Ambient Operating Temperature Range		15° to 50°C (59° to 122°F)						
Storage Temperature Range		-20° to 80°C (-4° to 176°F)						
Storage Humidity Range		0 to 95% Relative Humidity, non-condensing						

¹ Includes controller error, linearity, hysteresis and repeatability.

² Includes linearity, hysteresis and repeatability.

³ Control tuning required for optimum performance.

⁴ Consistent with the overpressure limit of the transducer.

Ordering Information

Contact MKS Applications Engineering for ordering code.	Code
Model	
P Series Dual-Zone Pressure Controller	PDPCA
Full Scale Pressure Range	
20 Torr	21T
50 Torr	51T
100 Torr	12T
Full Scale Flow Rate (He equivalent)	
20 sccm	21
50 sccm	51
100 sccm	12
Unit Configuration	
DeviceNet	6
Firmware	
DeviceNet Firmware	10
Gas and Bleed Flow Rate (Consult Applications Engineering)	

