

MKS R Series Gate Valve is available in both Aluminum and Stainless Steel configurations.

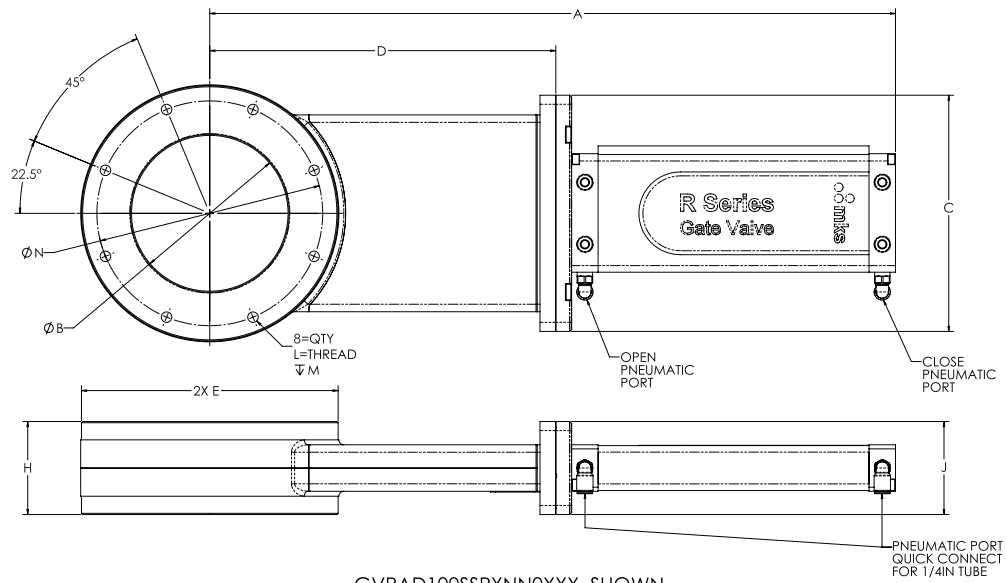

GVRAD100SSPXNN0XXX SHOWN

Pneumatic Actuation, SS										
Flange Size	A	B	C	D	E	H	J	L	M	N
DN080	16.27 [413]	3.14 [80]	6.00 [152.4]	7.68 [195]	5.71 [145]	2.36 [60]	2.36 [60]	M8 x 1.25-6H	0.47 [12]	4.92 [125]
DN100	17.34 [440.4]	3.96 [100.6]	6.00 [152.4]	8.75 [222]	6.49 [165]	2.36 [60]	2.36 [60]	M8 x 1.25-6H	0.47 [12]	5.71 [145]
DN160	23.12 [587]	5.91 [150]	8.85 [225]	12.20 [310]	8.82 [224]	2.76 [70]	2.44 [62]	M10 x 1.5-6H	0.59 [15]	7.87 [200]

Stainless Steel Gate Valve with Pneumatic Actuator

Note: Unless otherwise specified, dimensions are nominal values in inches (mm referenced).

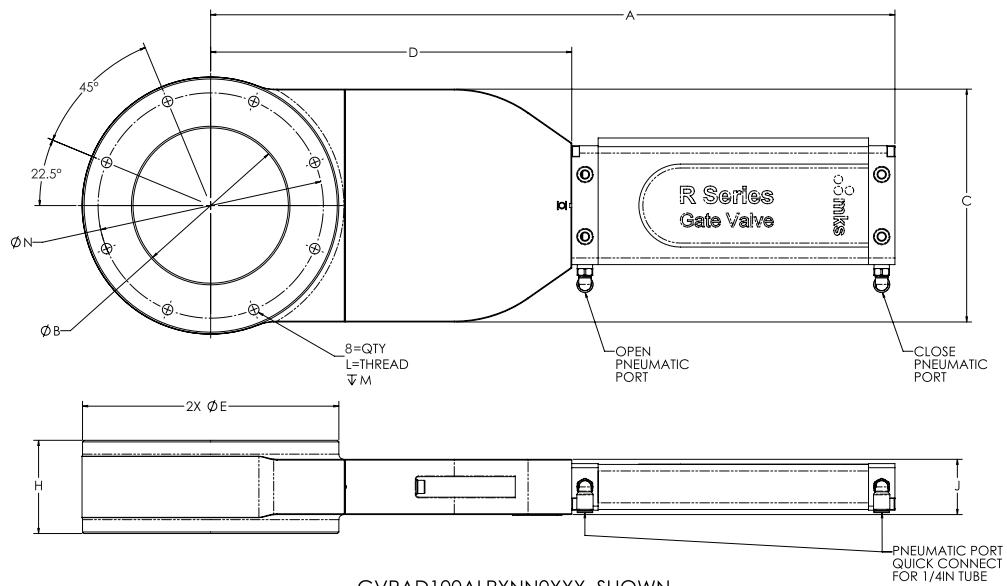

GVRAD100ALPXNN0XXX SHOWN

Pneumatic Actuation, AL										
Flange Size	A	B	C	D	E	H	J	L	M	N
DN100	17.34 [440.4]	3.94 [100]	5.90 [150]	9.15 [232.4]	6.50 [165]	2.36 [60]	1.40 [35.6]	M8 x 1.25-6H	0.43 [11]	5.71 [145]

Aluminum Gate Valve with Pneumatic Actuator

Note: Unless otherwise specified, dimensions are nominal values in inches (mm referenced).

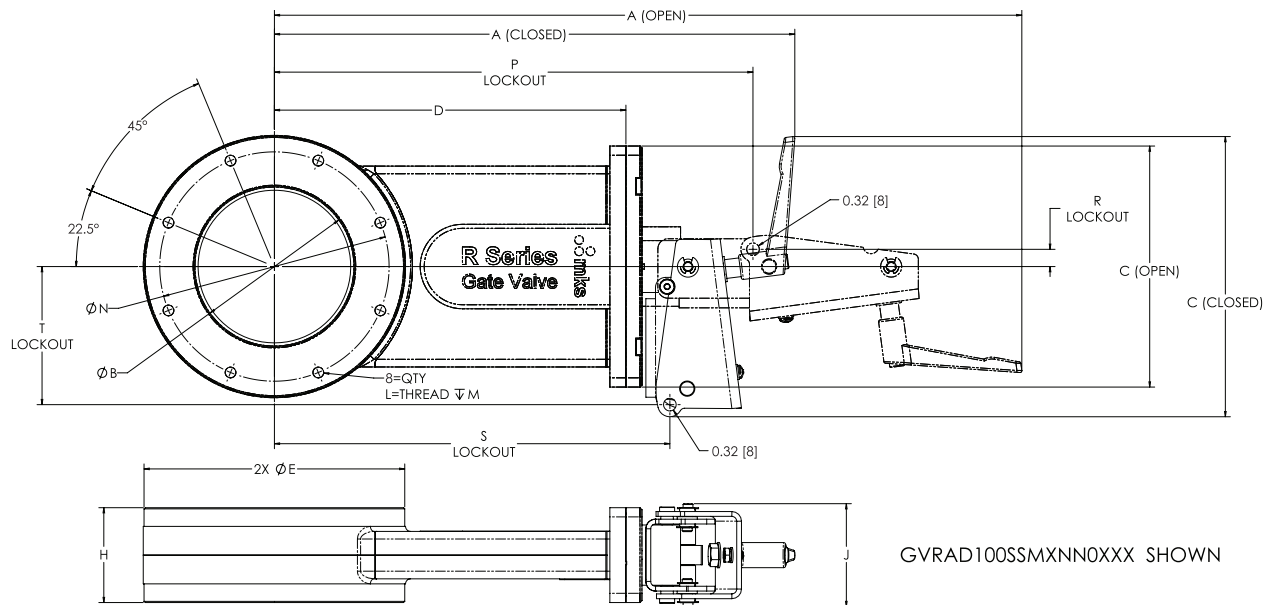

Manual Actuation, SS																
Flange Size	A (Open)	A (Closed)	B	C (Open)	C (Closed)	D	E	H	J	L	M	N	P Lockout (Open)	R Lockout (Open)	S Lockout (Close)	T Lockout (Close)
DN080	18,24 [463]	12,59 [320]	3,14 [80]	6,00 [152,4]	6,97 [177]	8,38 [213]	5,71 [145]	2,36 [60]	2,56 [65]	M8 x 1,25-6H	0,47 [12]	4,92 [125]	11,55 [293,3]	0,43 [11]	9,48 [240,8]	3,44 [87,3]
DN100	18,61 [472,6]	12,95 [329]	3,96 [100,6]	6,00 [152,4]	6,97 [177]	8,75 [222]	6,49 [165]	2,36 [60]	2,56 [65]	M8 x 1,25-6H	0,47 [12]	5,71 [145]	11,91 [302,6]	0,43 [11]	9,84 [250]	3,44 [87,3]
DN160	25,01 [635]	17,75 [451]	5,91 [150]	8,85 [225]	9,38 [238]	12,20 [310]	8,82 [224]	2,76 [70]	2,60 [66]	M10 x 1,5-6H	0,59 [15]	7,87 [200]	16,39 [416,2]	0,66 [16,7]	13,26 [336,7]	4,67 [118,7]