

# P9B

## Pressure Insensitive, Multi-Gas/Multi-Range Mass Flow Controller for Fast and Accurate Control of Critical Process Gases



The MKS, model P9B MFC, is the next generation of MKS pressure insensitive, multi-gas/multi-range MFC for critical process gas flow control. The device uses the latest in electronics and valve components enabling it to meet the most critical of process gas flow control requirements.

The performance capabilities of the P9B are quickly apparent where short process steps are required given the sub 750 millisecond control times and accuracy to within 1% of set point. This performance extends over the range of process gases, whether "light" gases such as helium or "heavy" gases like SF<sub>6</sub>. The P9B is a true multi-range/multi-gas MFC that enables the user to have confidence in this device's capability and minimize MFC inventory requirements.

Utilization of the multi-gas/multi-range capability is made simple through the device's embedded software and standard Ethernet interface that requires no special software, only a standard web browser and a PC. Already stored on the device are critical gas parameters for most of the gases in use today by the semiconductor industry. It is a simple matter of selecting the gas and specifying the range to configure the device. Through this interface the user can also perform device monitoring diagnostics while the device is operating.

### Product Features

- Fast response to set point reduces flow stabilization time for short process steps and process control
- Tightly controlled flow accuracy of process gas enables improved chamber process matching
- Insensitive to upstream and downstream pressure disturbances
  - Accurate flow control without the need for additional dedicated pressure regulators
- Accurate flow control over a wide dynamic range, even when down ranged, reduces need for an additional low range MFC
- Embedded configuration and diagnostics software that allows the user to check MFC functionality without device removal from the tool
- Uses a standard web browser; no special software required



### Key Benefits

- Reduces MFC inventory through its multi-gas/multi-range capability
- Easy viewing of flow rate, gas type and Full Scale flow with its bright, self orienting LED display

## Performance

<b>Full Scale Ranges (N<sub>2</sub> equivalent)</b>	5 - 50000 sccm
<b>Maximum Inlet Pressure</b>	150 psig (can not exceed pressure differential requirement across MFC)
<b>Normal Operating Pressure Differential (N<sub>2</sub> Full Scale) (with atmospheric pressure at the MFC outlet)</b>	<ul style="list-style-type: none"> <li>• 10 to 5000 sccm; 10 to 40 psid</li> <li>• 10000 to 20000 sccm; 15 to 40 psid</li> <li>• 30000 to 50000 sccm; 25 to 40 psid</li> </ul>
<b>Proof Pressure</b>	1000 psig
<b>Burst Pressure</b>	1500 psig
<b>Control Range</b>	2% to 100% of Full Scale (range on mech.)
<b>Typical Accuracy</b>	<ul style="list-style-type: none"> <li>• ±1% of set point for 20 to 100% Full Scale</li> <li>• ±0.2% of Full Scale for 2 to 20% Full Scale</li> </ul>
<b>Repeatability</b>	±0.3% of Reading
<b>Resolution</b>	0.1% of Full Scale
<b>Temperature Coefficients</b>	<b>Zero Span</b> <ul style="list-style-type: none"> <li>• &lt;0.05% of Full Scale./°C</li> <li>• &lt;0.08% of Reading./°C</li> </ul>
<b>Inlet Pressure Coefficient</b>	<0.02% of Reading/psi
<b>Typical Controller Settling Time (per SEMI Guideline E-17-0600)</b>	<750 msec., typical above 5% F.S.
<b>Warm-up Time (to within 0.2% of Full Scale of steady state performance)</b>	<30 min
<b>Operating Temperature Range (Ambient)</b>	10°C to 50°C
<b>Storage Humidity</b>	0 to 95% relative humidity, non-condensing
<b>Storage Temperature</b>	-20° to 80°C (-4° to 149° F)
<b>Pressure Display</b>	0 to 100 psia
<b>Pressure Readout Units</b>	psia, kPA
<b>Pressure Accuracy</b>	1% Full Scale
<b>Pressure Resolution</b>	0.1 psia
<b>Temperature Display</b>	0 to 100°C
<b>Temperature Readout Units</b>	°C
<b>Temperature Accuracy</b>	±2°C
<b>Temperature Resolution</b>	0.1°C
<b>Attitude Insensitivity</b>	0.25% of Full Scale for indicated zero, span and actual span
<b>Pressure Transient (Inlet/Outlet Pressure Sensitivity)</b>	±5% of set point from 20 to 100% of Full Scale when subject to a 2 psi inlet pressure transient

## Mechanical

<b>Fittings (compatible with)</b>	Swagelok® 4 VCR®, 1-1/8" surface mount (C-seal, W-seal), 1½" W-seal
<b>Display</b>	<ul style="list-style-type: none"> <li>• 4 digits for value, 4 characters for unit</li> <li>• No display on EtherCAT configurations</li> </ul>
<b>Leak Integrity</b>	<b>External (scc/sec He) Through Closed Valve</b> <ul style="list-style-type: none"> <li>• &lt;1 x 10<sup>-10</sup></li> <li>• &lt; 1.0% of Full Scale at 25 psig inlet to atmosphere (range on mech.) (To assure no flow-through, a separate positive shut-off valve is required.)</li> </ul>
<b>Wetted Materials</b>	<b>Standard Valve Seat</b> <ul style="list-style-type: none"> <li>• 316L S.S. VAR (equivalent to 316 S.S. SCQ for semiconductor quality), 316 S.S., Elgiloy®, KM-45</li> <li>• PTFE (Teflon)</li> </ul>
<b>Surface Finish</b>	10µ inch average Ra
<b>Weight</b>	<3 lbs (1.4kg)

Electrical Analog I/O		
Input Power Required	+15 to +24 VDC @ 350mA max	
Flow Input/Output Signal	0 to 5 VDC	
Output Impedance	< 1 Ω	
Connector	15-pin Type "D" Male, 9 pin Type "D" Male	
Compliance	CE	
Digital I/O	DeviceNet™	EtherCAT®
Input Power Required	+11 to +25 VDC per DeviceNet specification (@ <3.5 watts)	+24 VDC (<5 watts)
Connector	5 pin microconnector (DeviceNet)	2 x RJ-45 (comm.) male, M8 male, 5 pin (power)
Data Rate Switch	4 positions: 125, 250, 500K (Default), PGM (programmable over the network)	No switch
Data Rate/Network Length	Data rate (user selectable) <ul style="list-style-type: none"> <li>• 125 Kbps, 500 meters (1,640 feet)</li> <li>• 250 Kbps, 250 meters (820 feet)</li> <li>• 500 Kbps, 100 meters (328 feet)</li> </ul>	100 Mbps
MAC ID Switches	2 switches, 10 positions; 0,0 to 6,3 are hardware ID numbers; 7,0 to 9,9 are software ID numbers; (6,4 to 6,9 are unused and, if selected will default to hardware ID number 6,3)	3 switches, 16 positions
Network Size	Up to 64 nodes	Up to 4095 nodes
Network Topology	Linear (trunkline/dropline) power and signal on same network cable	N/A
Visual Communication Indicators	<ul style="list-style-type: none"> <li>• LED network status (green/red)</li> <li>• LED module status (green/red)</li> <li>• Scrolling LED displays (MFC Type, Flow Full Scale, Gas Type, IP address, Instance Number (1 to 31))</li> </ul>	<ul style="list-style-type: none"> <li>• LED Power (green)</li> <li>• LED Run (green)</li> <li>• LED Error (red)</li> <li>• LED Comm (green)</li> </ul>
Compliance	CE	CE

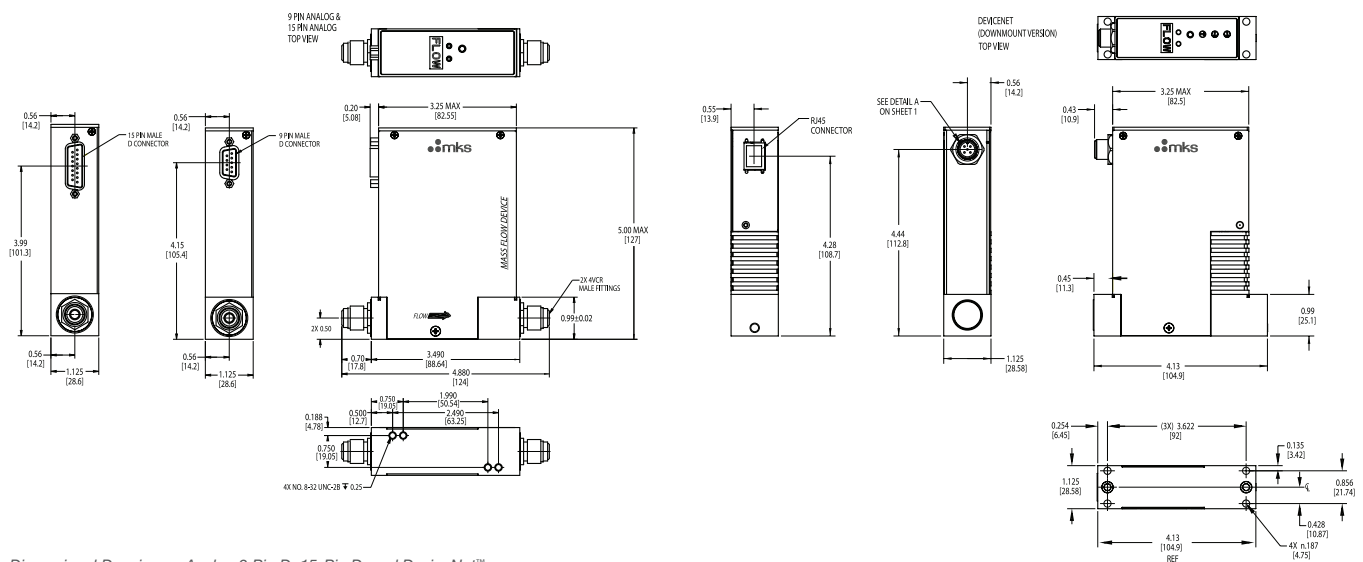

Dimensional Drawing — Analog 9 Pin D, 15-Pin D, and DeviceNet™  
 Unless specified, dimensions are nominal values in inches (mm referenced).

Ordering Code Example: P9B013502C8T010	Code	Configuration
<b>Model</b>		
MFC Mass Flow Controller (multigas, multi-range)	P9B	P9B
<b>Gas (per Semi Standard E52-0703)</b>		
013 = Nitrogen = N <sub>2</sub> 029 = Ammonia = NH <sub>3</sub> 110 = Sulfur Hexafluoride = SF <sub>6</sub>	013 029 110	013
<b>Flow Range Full Scale*</b>		
5 sccm 10 sccm 20 sccm 50 sccm 100 sccm 200 sccm 500 sccm 1000 sccm 2000 sccm 5000 sccm 10000 sccm 20000 sccm 30000 sccm 50000 sccm	500 101 201 501 102 202 502 103 203 503 104 204 304 504	502
<b>Fittings (compatible with)</b>		
Swagelok 4 VCR C-seal (1.125") W-seal (1.125") W-seal (1.15")	R C H F	C
<b>Connector</b>		
EtherCAT DeviceNet 15 pin D (Analog I/O) 9 pin D (Analog I/O)	8 6 B A	8
<b>Valve</b>		
Normally Closed, Teflon®: (5 sccm - 50 slm N <sub>2</sub> equivalent)	T	T
<b>Reserved for MKS Future Use</b>		
Standard	0	0
<b>Firmware</b>		
EtherCAT All Other I/O Unless otherwise specified, MKS will ship firmware revision current to date.	10 30	10

\* The Full Scale flow rate is designated by a 3 digit number. The first two digits represent the significant digits of the Full Scale flow rate separated by a decimal point. The third digit is the exponent of the power of ten.  
 254 is 2.5 x 10<sup>4</sup> or 25000 sccm      153 is 1.5 x 10<sup>3</sup> or 1500 sccm      601 is 6.0 x 10<sup>1</sup> or 60 sccm

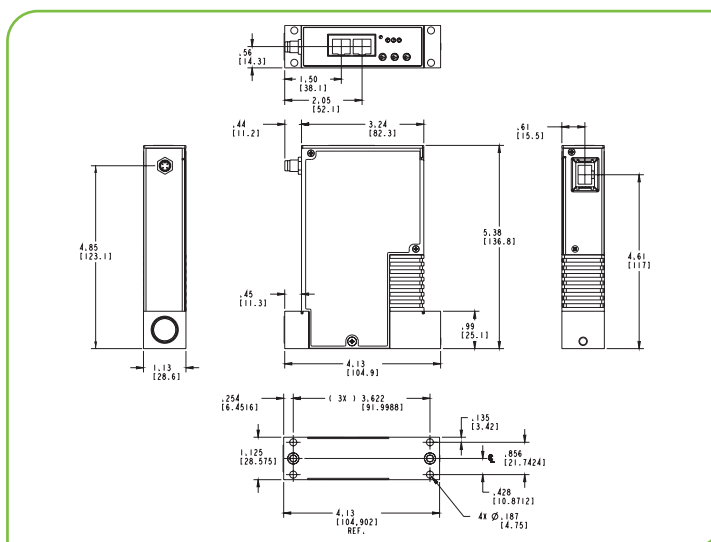

Dimensional Drawing — EtherCAT® Downmount  
 Unless specified, dimensions are nominal values in inches (mm referenced).